

FPGA-based multifunction PCI I/O, counter and encoder board, optically isolated, with fully programmable real-time functions

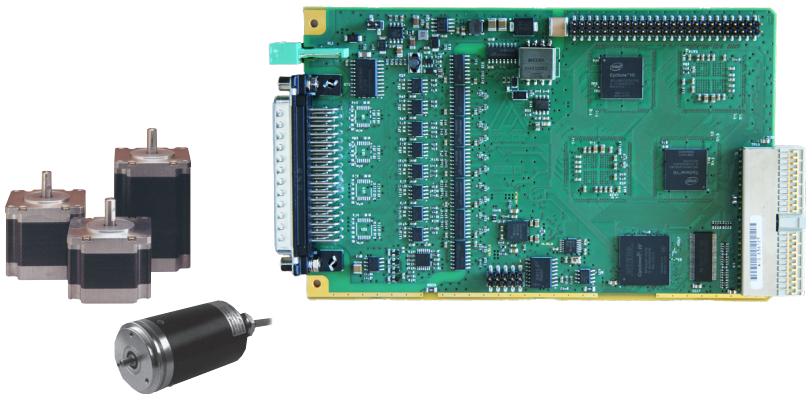

Also for APCI-1712

Also for
PCI EXPRESS
PCIe-1712



Windows 11
64/32-bit drivers



On request

The CPCI-1712 is a high-performance multifunction counter and digital I/O card for the PCI bus, designed for demanding industrial measurement and control applications. Based on an FPGA-driven architecture, the CPCI-1712 provides four independently configurable function modules.

Each module can be programmed with a wide range of counter, measurement, and logic functions via the supplied software, allowing the board to be precisely adapted to application-specific requirements.

Contact us!

Features

- 32-bit data access
- Up to 40 MHz input frequency
- Signals in TTL or RS422 mode (CPCI-1712), 24 V signals (CPCI-1712-24V)
- 4 on board FPGAs
- Software reprogrammable FPGA functions

Functions

- Incremental counter for the acquisition of incremental encoders (90° phase-shifted signals)
- SSI synchronous serial interface. The SSI function is an interface for systems which allow an absolute position information via serial data transfer.
- BiSS-C
- Counter/timer (82C54)
- Pulse acquisition
- Frequency measurement
- Pulse width modulation (PWM)
- Period duration measurement
- Velocity measurement
- Digital inputs and outputs
- Edge time measurement (ETM)
- **Customised functions**

Available channels for all four function modules

- 20 channels for digital inputs, optically isolated
- 8 channels, programmable either as digital inputs or outputs, optically isolated
- 4 digital power outputs, optically isolated

CPCI-1712

Available functions:

Four programmable Altera Cyclone 10 FPGAs

Multifunction counter and I/O capabilities :

Incremental Counter, SSI, Counter, Timer, PWM, others on request (Sin/Cos, ENDAT ...)

Supports high-frequency input signals, suitable for fast encoder and pulse-based applications

Galvanic isolation of inputs

Input and Outputs: TTL, RS422, 24V

Software-configurable and upgradable

Available lines for each function module

8 lines are available for each function module

- Input lines:
 - 2 x TTL and RS422 (CPCI-1712) or 2 x 24 V (CPCI-1712-24V)
 - 3 x 24 V, optional 5 V for channels E, F, G
- Output lines:
 - 1 x 24 V, optional 5 V (power output)
- 2 channels, programmable either as digital inputs or outputs, optically isolated: 2 x TTL, RS422
- Galvanic Isolation (Inputs) 1000V

Applications

- Event and batch counting
- Position and speed acquisition
- Encoder feedback and motion control
- Conveyor tracking and synchronization
- Vision system triggering
- Production monitoring and quality control
- Frequency and pulse measurement

Software drivers

Standard drivers for:

- Linux
- 64 bits Windows 7 / 8 / 10 / 11
- On Request : RTX, Xenomai, VxWorks, QNX

Supported Drivers Languages :

- C/C++
- Python
- .NET
- Other on Request

On request:

Documentation and developer resources.

The software functions can be adapted to your applications on request. The board can also be implemented for other software applications.

Service

- Integration in MSX-BOX DAQ IPC possible for ready to use solutions
- Long Term availability (20+)

Wide range of applications through free combination of function modules on FPGA

4 function modules quickly and easily programmable with numerous functions

Each of the four modules is programmed with one function. You can program 4 times the same function or freely combine 4 different functions.

Configuration example 1			
Function module 0	Function module 1	Function module 2	Function module 3
32-bit Incremental counter	32-bit Incremental counter	Pulse counter	Counter/Timer

Configuration example 2			
Function module 0	Function module 1	Function module 2	Function module 3
SSI	SSI	32-bit Incremental counter	Digital I/O, 24 V

Programmable onboard modules

The CPC1-1712 is fully integrated into the ADDI-DATA Ecosystem and Software. Each onboard module can be configured with the required function using ConfigTools, the graphical configuration tool delivered as part of the ADDI-DATA software environment.

Up to four different functions can be operated simultaneously on a single board. Application changes are implemented quickly and easily by reconfiguring the modules via ConfigTools, without any hardware modification, ensuring flexibility throughout the product lifecycle.

Overview of signal generators resp. functions

Application	Max. number of signal generators or functions for each function module	Max. number of function modules for each CPC1-1712	Max. number of signal generators or functions of each CPC1-1712	Page
Incremental encoder	1 (32-bit) or 2 (16-bit)	4	4 or 8	3
SSI	3	4	12	3
Chronos	1	4	4	4
Counter/Timer	3	4	12	5
TOR	2	4	8	6
Pulse counter	4	4	16	7
PWM	2	4	8	7
ETM	2	4	8	8
Digital I/O	8	4	32	8
TTL	24	1	24	-

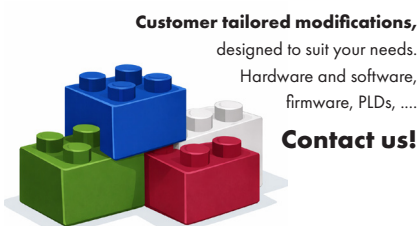

Simplified block diagram

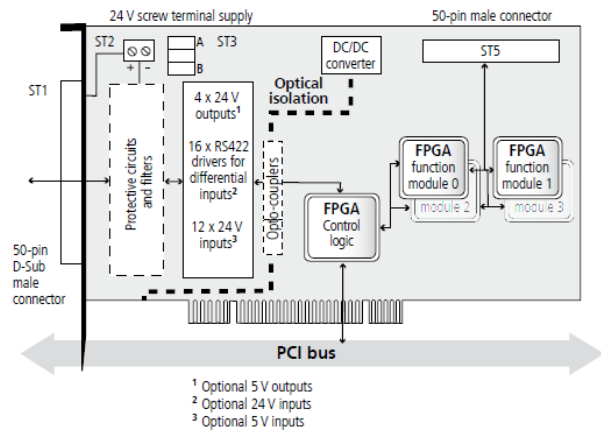

Pin assignment

Pin	Pin	Pin	Pin
34 +UREF	18 A2+	34 18	1 EXTGND
35 HO*	19 A2-	35 2	2 A0+
36 H1*	20 B2+	36 3	3 A0-
37 H2*	21 B2-	37 4	4 B0+
38 H3*	22 C2+	38 5	5 B0-
39 E0*	23 C2-	39 6	6 C0+
40 E1*	24 D2+	40 7	7 C0-
41 E2*	25 D2-	41 8	8 D0+
42 E3*	26 A3+	42 9	9 D0-
43 F0*	27 A3-	43 10	10 A1+
44 F1*	28 B3+	44 11	11 A1-
45 F2*	29 B3-	45 12	12 B1+
46 F3*	30 C3+	46 13	13 B1-
47 G0*	31 C3-	47 14	14 C1+
48 G1*	32 D3+	48 15	15 C1-
49 G2*	33 D3-	49 16	16 D1+
50 G3*		50 17	17 D1-

*Each number corresponds to the number of the function module

ConfigTools



Select the function you want to load.

Save when the configuration is complete.

Function Incremental encoder

Up to 2 **incremental encoders** can be connected to a module programmed with the function Incremental encoder. The applications are :

- 90° phase-shifted input signals (displacement measurement systems)
- Motion control
- Pulse width and frequency measurement
- Incremental encoder acquisition
- Tolerance measurement
- Velocity measurement
- Rotation measurement
- Electronic "mouse"

Function range of the counter component

- Simple, double, quadruple analysis of 2 phase-shifted clock pulses (A, B)
- Direction recognition for upwards or downwards counting
- Hysteresis circuit for the absorption of the first pulse after a change in rotation; switchable
- 2 x 32-bit data latches, indiv. programmable for internal / external strobe, latch strobe synchronised with an internal clock pulse
- Operating mode is defined by an internal mode register, loadable and readable through the data bus
- Strobe inputs which can be triggered either through 2 external pins (24 V input) or by writing in a register
- Interrupt indication triggered through the external strobe inputs
- Compare logic, interrupt and reference point logic

Used signals

Signal name	Pin name	Signal type	Function
A_x	Ax +/-	Diff./TTL/24 V*	A signal of the incremental encoder (32-bit) resp. A signal of the incremental encoder 0 (16-bit)
B_x	Bx +/-	Diff./TTL/24 V*	B signal of the incremental encoder (32-bit) resp. B signal of the incremental encoder 0 (16-bit)
INDEX_x	Cx +/-	Diff./TTL/24 V*	Index signal of the incremental encoder (32-bit)
C_x	Cx +/-	Diff./TTL/24 V*	A signal of the incremental encoder 1 (2x16-bit)
UAS_x	Dx +/-	Diff./TTL/24 V*	Error signal input (32-bit)
D_x	Dx +/-	Diff./TTL/24 V*	B signal of the incremental encoder 1 (2x16-bit)
REF_x	Ex	24 V / 5 V optional	Digital input (can also control the reference point logic)
ExtStrb_a_x	Fx	24 V / 5 V optional Active High	Digital input (can be used for latch logic, respectively generate an interrupt)
ExtStrb_b_x	Gx	24 V / 5 V optional Active High	Digital input (can be used for latch logic, respectively generate an interrupt)
DIG_OUT_x	Hx	24 V / optional 5 V	Digital output

x: Number of the function module (See pin assignment page 2)
* 24 V for the CPCI-1712-24 V

Function Synchronous serial interface (SSI)

The function module is programmed as a synchronous serial interface. The **SSI** function is an interface for systems which allow an absolute position information through serial data transfer.

Typical application examples:

- Acquisition of displacement measurement systems
- Axis control (X, Y and Z)
- Tolerance measurement ...



Properties

- 4 function modules for each board, up to 3 SSI encoders per function module (depends on encoder)
- Optical isolation of the inputs and outputs through opto-couplers to prevent ground loops
- Serial data transfer
- Common clock pulse for the 3 interfaces per function module
- Clock frequency and number of data bits are software-programmable
- GRAY to BINARY conversion possible
- For each function module there are 3 digital inputs and 1 digital output for an additional function (no effect on SSI function)

The interface includes:

- Three independent 32-bit SHIFT registers, which can be read through the data bus
- Clock and pulse generator
- Function and control logic

Block diagram SSI

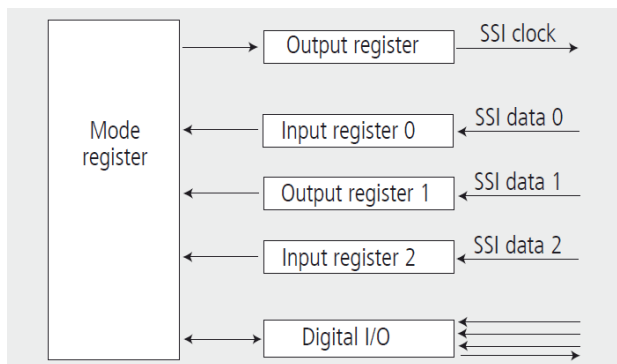

Used signals

Signal name	Pin name	Signal type	Function
Clock_x	Ax +/-	RS422	Clock output signal for the SSI encoders
DATA1_x	Bx +/-	RS422/TTL	Data input 1 for the first encoder
DATA2_x	Cx +/-	RS422/TTL	Data input 2 for the second encoder
DATA3_x	Dx +/-	RS422/TTL	Data input 3 for the third encoder
Input1_x	Ex	24 V / 5 V optional	Digital input 1
Input2_x	Fx	24 V / 5 V optional	Digital input 2
Input3_x	Gx	24 V / 5 V optional	Digital input 3
Output_x	Hx	24 V / 5 V optional	Digital output

x: Number of the function module (See pin assignment page 2)
The SSI function cannot be programmed on the CPCI-1712-24 V.

Function Chronos

The function **Chronos** is a timer interface which allows to measure the time between two "events" like a chronometer.

3 functions are available:

- a 32-bit timer to create a time reference,
- a 32-bit measuring timer to determinate and measure the time between start and stop pulse.
- 3 digital inputs and 3 digital outputs

Properties

- Optical isolation of the inputs and outputs through opto-couplers to prevent ground loops
- Interrupt status at the end of the measuring time
- Timer readable
- Input and output channels can be inverted through software, Software GATE possible

Function description

The pulse signals from Timer 0 are counted between the start pulse signal and the stop pulse signal. The number of pulses is then stored in the measuring timer and can be read through I/O read commands. The timer 0 is used as a time reference generator. The divider factor is written in timer 0 and determines the output frequency.

The input frequency is set according to the PCI clock pulse or to the 10 MHz onboard clock generator. Timer 0 is synchronised with the start event or with the 40 MHz quartz of the board. Timer 0 can be read at any time. The Chronos function can be used in 8 different modes.

Used signals

Pin name	Signal type	Function
Ax +/-	Diff./TTL, 24 V*	Digital output 1; set to "0" after reset
Bx +/-	Diff./TTL, 24 V*	Digital output 2; set to "0" after reset
Cx +/-	Diff./TTL/24 V*	Start pulse for measuring
Dx +/-	Diff./TTL/24 V*	Stop pulse for measuring
Ex	24 V / 5 V optional	Digital input 0, inverting
Fx	24 V / 5 V optional	Digital input 1, inverting
Gx	24 V / 5 V optional	Digital input 2, inverting
Hx	24 V / 5 V optional	Digital output 0; set to "0" after reset

x: Number of the function module (See pin assignment page 2)

*24 V for the CPCI-1712-24V

Block diagram Chronos

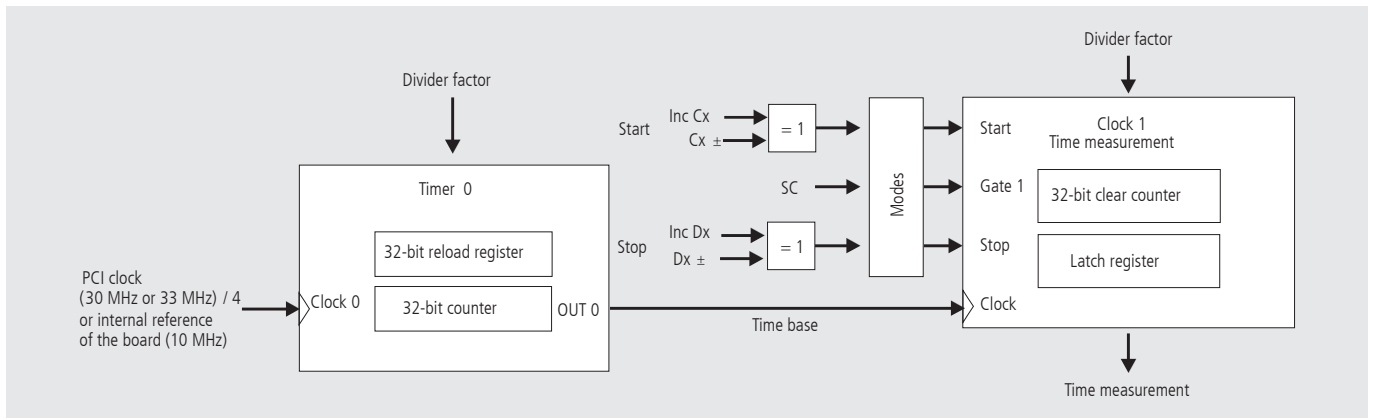

Function Counter/Timer

Function equivalent to Intel 82C54

The module **Counter/Timer** can be used as a programmable interval counter/timer (similar to Intel 82C54) with 3 x 32-bit per module.

It generates time delays through software control. Instead of setting up timing loops in software, the user programs the module for the desired delays. After this delay, the module will interrupt the PC.

- Optical isolation of the inputs and outputs through opto-couplers to prevent ground loops
- 3 x 32-bit counters/timers, binary counting only
- 6 programmable modes
- Status readback and latch command
- Inputs and outputs can be inverted through software
- Hardware and software gate possible, readable
- Simple interface: no multiple assignment of the addresses
- Interrupt enabled with an individual release bit per counter/timer and interrupt status register

Typical applications:

- Event counter
- Programmable rate generator
- Binary rate multiplier
- Square-wave generator
- Complex motor controller / signal generator

Programmable modes

For each counter/timer (3 x 32-bit) there are 6 modes available: mode 0 to mode 5, which can be programmed independently.

Mode 0: Interrupt on terminal count

Mode 0 is particularly suitable for event counting. The output is initially set to "Low" and remains "Low" until the counter reaches 0. The output then goes "High" and holds this state until a new count or a new counter value is written into the counter.

Mode 1: Hardware retriggerable one-shot

This mode is identical to mode 0 except for the GATE input. The GATE input is not used to activate or deactivate the timer, but to trigger it.

Mode 2: Pulse generator

In this mode the counter is dividing the choosed input clock through the start value "ul_ReloadValue". Mode 2 is used for generating a real-time clock interrupt. After initialization the output is set to "High". When the initial count has decremented to 1, the output goes "Low". For only one clock pulse the output is set to "Low" then it goes back to "High". The counter reloads the start value ("ul_ReloadValue") and the counter sequence is repeated. The number of sequences is unlimited. An interrupt can be generated at the end of the cycle. Calculation of time: $(ul_ReloadValue + 2) \times \text{input clock}$

Mode 3: Square wave mode

Mode 3 is used for baud rate generation. It is similar to mode 2 except for the duty cycle of the output. The output is initially set to "High". When half the initial count has expired, the output is set to "Low" for the remainder of the count. Mode 3 is periodic; the same sequence is repeated indefinitely. Calculation of time: $(ul_ReloadValue + 2) \times \text{input clock}$

Mode 4: Software-triggered strobe

The output is initially set to "High". When the initial count expires, the output goes "Low" for one clock pulse and then goes "High" again. The counting sequence is triggered by writing the initial count.

If a new count is written during counting, it will be loaded on the next clock pulse and counting will continue from the new count.

Mode 5: Hardware-triggered strobe (retriggerable)

This mode is identical to mode 4 except for the GATE input. The GATE input is not used to activate or deactivate the timer, but to trigger it.

Used signals

Signal name	Pin name	Signal type	Function
OUT1_x	Ax +/-	Diff./TTL	Output of counter/timer 0
OUT2_x	Bx +/-	Diff./TTL	Output of counter/timer 1
OUT3_x	Hx	24 V / 5 V opt.	Output of counter/timer 2
GATE1_x	Ex	24 V / 5 V opt.	GATE Input of counter/timer 0
GATE2_x	Fx	24 V / 5 V opt.	GATE Input of counter/timer 1
GATE3_x	Gx	24 V / 5 V opt.	GATE Input of counter/timer 2
CLK1_x	-	-	Internal clock
CLK2_x	Cx +/-	Diff./TTL/ 24 V opt.	Clock counter input of counter/timer 1
CLK3_x	Dx +/-	Diff./ TTL/ 24 V opt.	Clock counter input of counter/timer 2

The Counter/Timer function cannot be programmed on the CPCI-1712-24 V.

x: Number of the function module (See pin assignment page 2)

Block diagram Counter/Timer

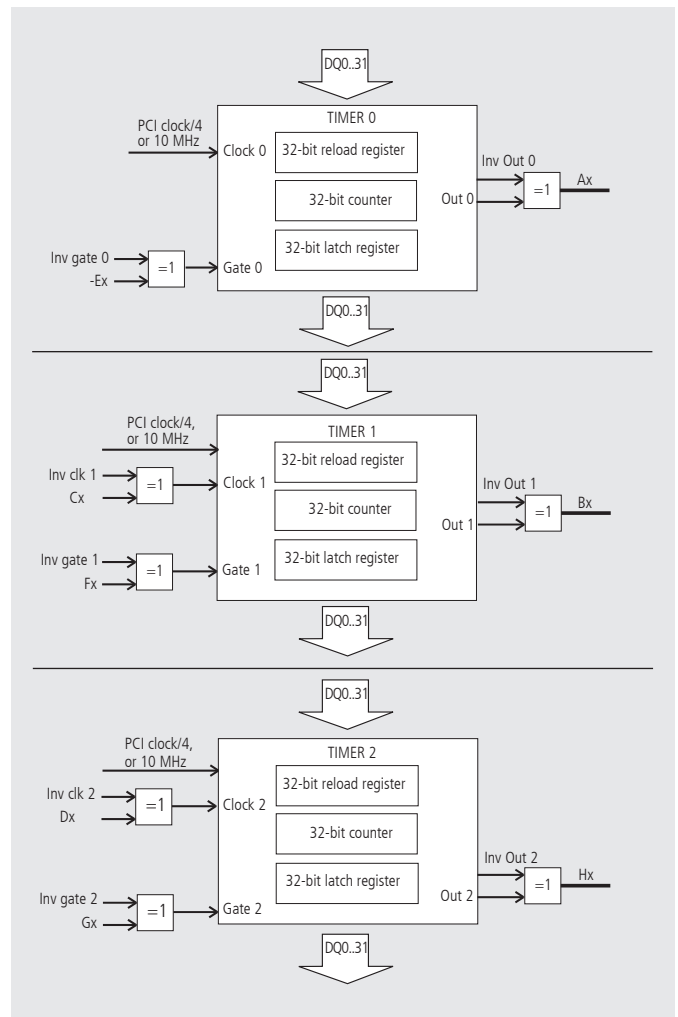

Function TOR

The **TOR** function is a counter interface which allows counting input signals in a defined time interval.

2 TOR counters are available on each function module. Each TOR counter includes 2 x 32-bit timers.

The TOR function is a scaled-down version of the Counter/Timer function. The pulse signal of Timer 1 gives the start and stop pulse signal to Timer 0. Timer 0 counts the input signals. After the stop signal from Timer 0 the number of pulses is stored and can be read through I/O read commands.

The timer 1 is used as a time reference generator.

The divider factor is written in timer 1 and determines the output frequency. The input frequency is set according to the PCI clock pulse or the 40 MHz on-board quartz clock. Timer 0 is synchronised with the start event.

Pulse measurement

As soon as a start signal occurs from Timer 1, the Timer 0 is reset.

It counts the pulse signals of the channel Ax(Bx).

During the process the status bit "Counter in Progress" is set.

As soon as a stop signal occurs from Timer 1, the Timer 0 is stopped and the status bit "Counter in Progress" is reset.

An interrupt can also be generated. The value can then be read. The latest measured value is read in the counter measurement register.

Properties

- Optical isolation of the inputs and outputs through opto-couplers to prevent ground loops
- Interrupt status at the end of the measuring period
- Inputs and output can be inverted through software
- Software GATE

The function TOR occupies 4 inputs (A to D) of the corresponding function module of the CPCI-1712.

Used signals

Pin name	Signal type	Function
Ax +/-	Diff./TTL/24 V*	Digital input 1 (TOR1)
Bx +/-	Diff./TTL/24 V*	Digital input 2 (TOR2)
Cx +/-	Diff./TTL/24 V*	External Gate (TOR1)
Dx +/-	Diff./TTL/24 V*	External Gate (TOR2)

x: Number of the function module (see pin assignment page 2)

*24 V for the CPCI-1712-24V

Block diagram TOR

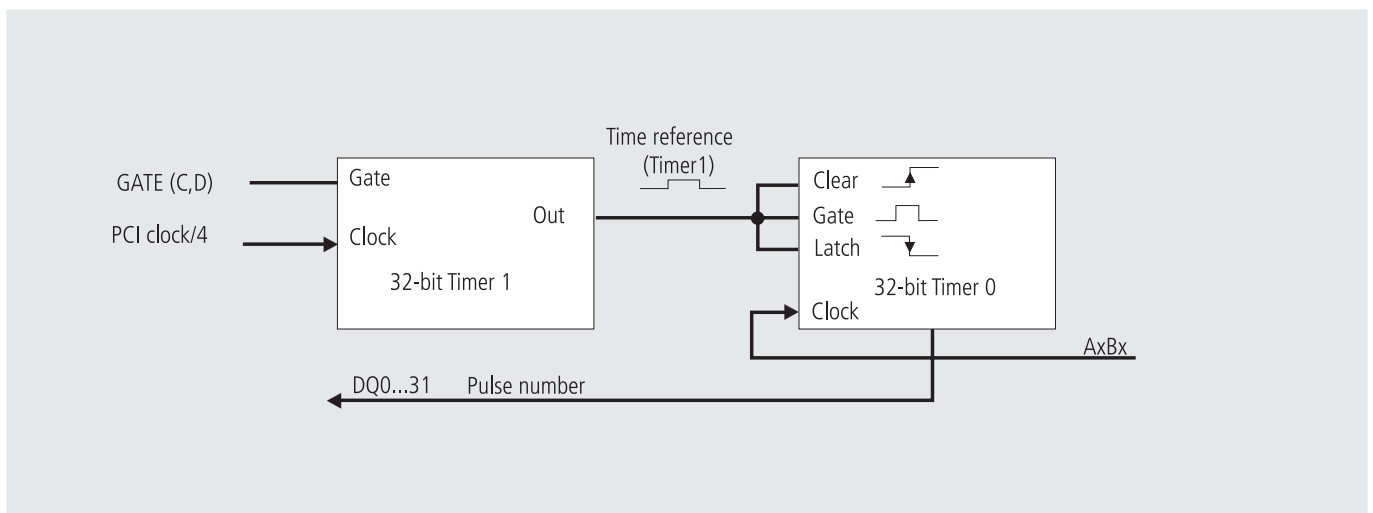

Function Pulse counter

The **Pulse counter** is an interface for the acquisition of external digital pulses. Each rising or falling edge on the counter input starts decrementing from the initially set counter value. An interrupt is generated at logical "0", i.e. the digital output is set or reset.

- 4 x 32-bit downward counters
- Optical isolation of the inputs and outputs through opto-couplers to prevent ground loops
- Each counter can be loaded with a predefined counter value
- Interrupt at overflow
- Output can be set or reset at overflow
- Polarity of the inputs selectable through software

The interface includes:

- 4 x 32-bit counters
- 4 independent 32-bit registers, readable through the data bus
- a function and control logic.

Used signals

Pin name	Signal type	Function
Ax +/-	Diff./TTL/24 V*	Input of the 1st counter
Bx +/-	Diff./TTL/24 V*	Input of the 2nd counter
Cx +/-	Diff./TTL/24 V*	Input of the 3rd counter
Dx +/-	Diff./TTL/24 V*	Input of the 4th counter
H	24 V/5 V optional	Common digital output of the counter

x: Number of the function module (see pin assignment page 2)
 * 24 V for the CPCI-1712-24V

Block diagram Pulse counter

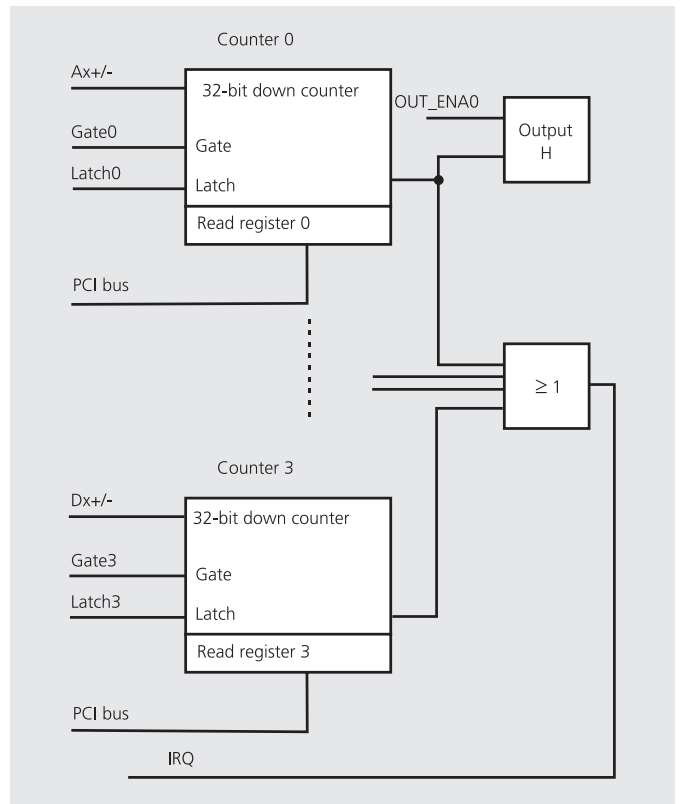

Function PWM (Pulse width modulation)

The PWM function provides a pulse-width modulation generator. It generates a configurable frequency and defines the duration (pulse width) of the Low and High levels.

PWM generator

The "Low/High" time-divider factors are written in the timer and determines the output frequency. The input frequency is set according to the PCI clock or the 40 MHz quartz of the board.

- The function includes:
- a 32-bit frequency generator for setting the "Low" and "High" levels
 - 2 digital inputs as start or stop trigger
 - 2 digital frequency outputs

Properties

- Optical isolation of the inputs and outputs through opto-couplers to prevent ground loops
- Interrupt status at the end of a period
- Selection of the start level
- Selection of the stop level
- Hardware gate
- Software gate

Typical applications

- Frequency generation
- Pulse width modulation
- Drive technology

Used signals

Signal name	Pin name	Signal type	Function
PWM_OUT_Ch0_x	Ax +/-	Diff./TTL output	digital output PWM 0
PWM_OUT_Ch1_x	Bx +/-	Diff./TTL output	digital output PWM 1
GATE_Ch0_x	Cx +/-	Diff./TTL input	Gate input PWM 0
GATE_Ch1_x	Dx +/-	Diff./TTL input	Gate input PWM 1
DIG_IN_E_x	Ex	24 V input	digital input
DIG_IN_F_x	Fx	24 V input	digital input
DIG_IN_G_x	Gx	24 V input	digital input
DIG_OUT_H_x	Hx	24 V output	digital output PWM 0 or freely controllable

x: Number of the function module (See pin assignment page 2)
 The PWM function only can be used restricted to the 24 V version. Only PWM0 is available for the DIG_OUT_H_x 24 V output.

Block diagram PWM

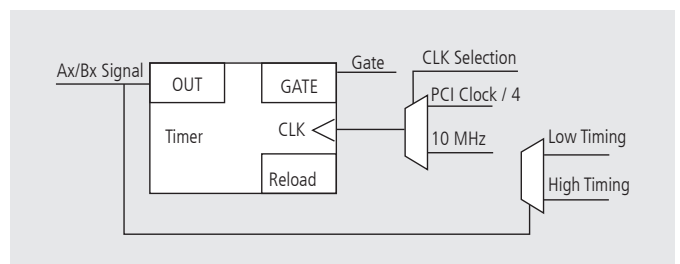

Function ETM (Edge Time Measurement)

The **ETM** function is a timer interface which allows measuring the duration of a period, and simultaneously, the "High" or "Low" level time of this period. A function module with the ETM function has

- 1 timer to create a time base
- 2 counters to measure the period duration
- 2 counters to measure the "High" or "Low" level time
- 2 gate inputs

The ETM function uses 4 inputs (A to D) with each function module of the CPCI-1712 or APCI-1712. Up to 8 ETM (2 per module) can be operated on one board.

Properties

- Optical isolation of the inputs and outputs through opto-couplers to prevent ground loops
- Interrupt status at the end of a period
- Timer can be read back
- Inputs and outputs can be inverted through software
- Software gate

Typical applications

Block diagram ETM

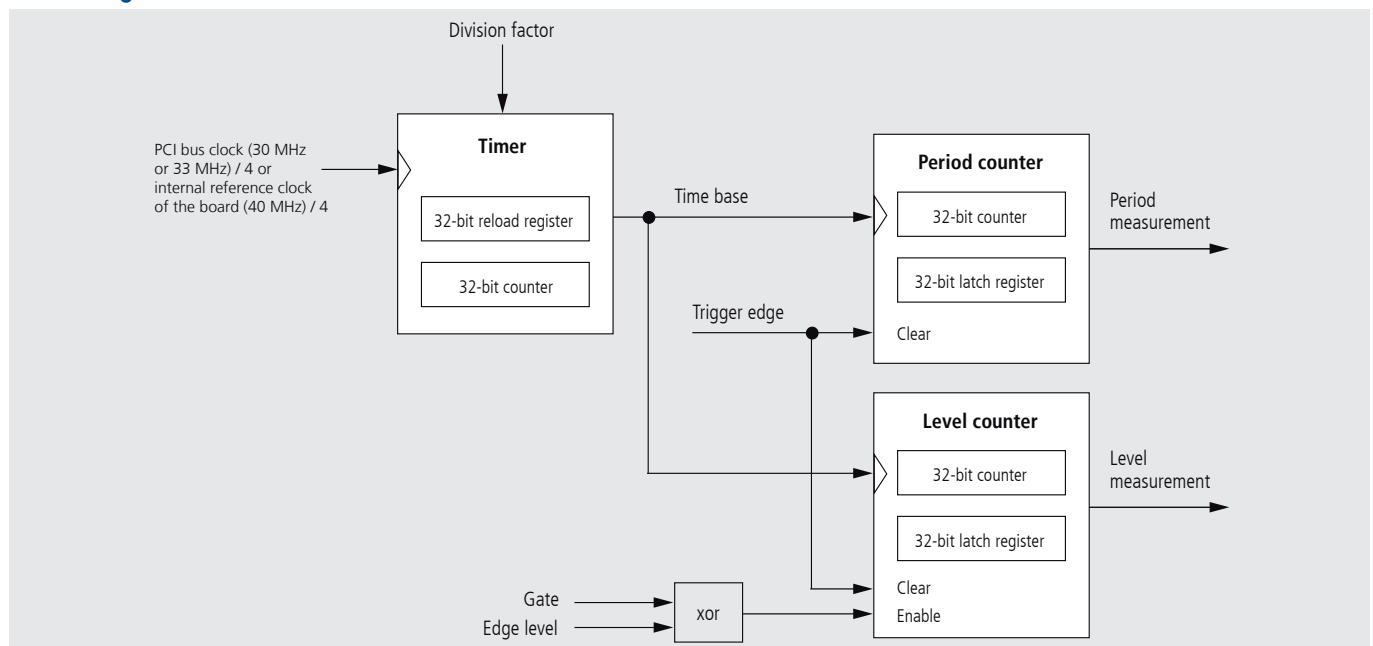

- Period duration measurement
- Level duration measurement

Used signals

Signal name	Pin name	Signal type	Function
Gate0_x	Ax +/-	Diff./TTL/opt. 24 V*	Gate input of ETM counter 0
Input0_x	Bx +/-	Diff./TTL/opt. 24 V*	Input of ETM counter 0
Gate1_x	Cx +/-	Diff./TTL/opt. 24 V*	Gate input of ETM counter 1
Input1_x	Dx +/-	Diff./TTL/opt. 24 V*	Input of ETM counter 1

x: Number of the function module (see pin assignment page 2)
*24 V for the CPCI-1712-24V

Function Digital input and output

The **Digital input and output** function allows an easy access to the digital I/O available on the function modules. The I/O level of the input and output channels are read and set or reset through read/write commands. The digital I/O have no logical connection to each other. The connection can only be made through software. The complete isolation through opto-couplers avoids earth circuits. The complete galvanic isolation using opto-couplers prevents ground loops between isolated circuits.

Available channels

- 3 x 24 V mass-related input channels, optional 5 V
- 2 x differential input channels (RS422/485), can also be used as TTL input channels
- 1 digital output, 24 V, load to ground (10 to 36 V / 500mA)
- 2 differential inputs or outputs (RS485), can also be used as TTL input or output channels. Software configuration.

When the digital I/O function is programmed on all function modules, up to 28 digital input and 12 digital output channels are available

Used signals

Pin name	Signal type	Function
Ax +/-	Diff./TTL/24 V*	Dig. input and output (with 24 V* only input)
Bx +/-	Diff./TTL/24 V*	Dig. input and output (with 24 V* only input)
Cx +/-	Diff./TTL/24 V*	Digital input
Dx +/-	Diff./TTL/24 V*	Digital input
Ex	24 V / 5 V optional	Digital input
Fx	24 V / 5 V optional	Digital input
Gx	24 V / 5 V optional	Digital input
Hx	24 V / 500 mA (10 – 36 V)	Digital output

x: Number of the function module (see pin assignment page 2)
*with the CPCI-1712-24V

Specifications

Counter components

Counting depth:	32-bit
Counting frequency:	Up to 5 MHz

Available functions

32-bit or 16-bit acquisition of incremental encoders
Acquisition of absolute encoders/SSI
Counter/timer
Chronos/TOR for frequency measurement
Pulse acquisition
Chronos for pulse width modulation
Chronos for period duration measurement
TOR for velocity measurement
Digital I/O, 24 V, TTL, RS422
PWM
ETM
Custom functions

Signals

Digital I/O signals, TTL or RS422

Inputs

Number of inputs:	20
-------------------	----

Differential inputs or outputs

5 V inputs:	8/16 (8 can be used as inputs or outputs)
Nominal voltage:	5 VDC
Common mode range:	+13 / -8 V
Max. differential voltage	±12 V
Input sensitivity:	105 mV
Input hysteresis:	10 mV
Input impedance:	High Impedance
Terminal resistor:	Not connected
Signal delay:	25 nS (at nominal voltage)
Max. input frequency:	2.5 MHz (at nominal voltage)

Mass-related inputs, 24 V (channels E, F, G):

Number of inputs:	12
Nominal voltage:	24 VDC
Input current:	35 µA (OPA buffered)
Logic input levels:	Unominal: 24 V UH max.: 30 V UH min.: 19 V UL max.: 17 V UL min.: 0 V

Signal delay:	1.3 µs (at nominal voltage)
Maximal input frequency:	2.5 MHz (at nominal voltage)
Galvanic Isolation:	1000V

Outputs

Nominal voltage:	3.3V
Maximum output frequency:	2.5 MHz (diff. outputs)
Max. number of outputs:	8 (if they are not used as diff. inputs)

Digital outputs, 24 V:

Output type:	High-side (load to ground)
Number of outputs:	4
Nominal voltage:	24 VDC
Range of the supply voltage:	5V to 35V (via 24 V ext. pin)
Maximum current for 4 outputs:	1.4 A typ. (limited to the voltage supply)
Maximum output current:	500 mA short-circuit current/
output at 24 V, $R_{load} < 0.1 \Omega$:	1.5 A max. (output switches off)
ON-resistance of the output (RDS ON resistance):	0.4 Ω max.

Overtemperature:	165 °C (all outputs switch off)
Overtemperature protection (24 V outputs)	
Activated:	From approx. 150-165 °C (chip temperature)
Deactivated (automatically):	Always activated
Outputs (at overtemperature):	Outputs switch off

Switching characteristics of the 24 V outputs

(V ext. = 24 V, T=25 °C, ohmic load: 500 mA):	
Switch ON time:	200 µs
Switch OFF time:	15 µs

Digital outputs, 5 V (option):

Output type:	TTL
Number of outputs:	4
Nominal voltage:	5 VDC

Switching characteristics of the 5 V outputs (T=25 °C, TTL load):

Switch ON time:	0.06 µs
Switch OFF time:	0.02 µs

Technical data for the CPCI-1712-24 V board version

24 V inputs (channels A to G). This board version is exclusively used for connecting 24 V encoders. Only 24 V signals can be connected to the input channels.

Nominal voltage:	24 VDC / 35 µA
Max. input frequency:	1 Mhz
Logic input levels :	U nominal: 24 V UH max.: 30 V UH min.: 19 V UL max.: 17 V UL min.: 0 V

EMC – Electromagnetic compatibility

The product complies with the European EMC directive. The tests were carried out by a certified EMC laboratory in accordance with the norm from the EN 61326 series (IEC 61326). The limit values as set out by the European EMC directive for an industrial environment are complied with. The respective EMC test report is available on request.

Physical and environmental conditions

Dimensions:	168 x 98 mm
System bus:	PCI 32-bit 5 V acc. to specification 2.1 (PCISIG)
Space required:	1 slot
Operating voltage:	+5 V, ± 5 % from the PC +24 V ext. /10 mA
Current consumption:	CPCI-1712-x: 1.15 A typ. ± 10 %
Front connector:	50-pin D-Sub male connector
Additional connector:	Male connector for the TTL I/O function
Temperature range:	0 to 60 °C (with forced cooling)

ADDI-DATA connection

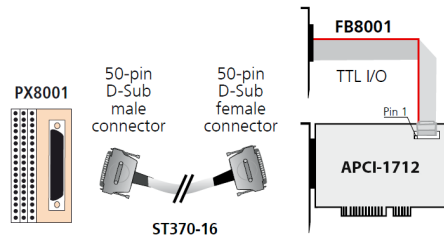

Ordering information

CPCI-1712

FPGA-based multifunction PCI I/O, counter and encoder board, optically isolated, with fully programmable real-time functions.

CPCI-1712: Multifunction counter board, optically isolated.

CPCI-1712-24V: 24 V for differential input signals (A and B for counter, I (Index) and UAS (error) signals).

CPCI-1712-5V-I: 5 V inputs (E, F, G) instead of 24 V

Option

Opt. 5V: 5 V outputs (H1, H2, H3, H4) instead of 24 V

Accessories

ST370-16: Shielded round cable, 2 m

PX8001: 3-row terminal panel for DIN rail

FB8001: Ribbon cable for connecting the TTL I/O function

