

TECHNICAL

DESCRIPTION

MSX-E3211

Ethernet system for temperature measurement



Product information

This manual contains the technical installation and important instructions for correct commissioning and usage, as well as production information according to the current status before printing.

The content of this manual and the technical product data may be changed without prior notice.

ADDI-DATA GmbH reserves the right to make changes to the technical data and the materials included herein.

Warranty and liability

The user is not permitted to make changes to the product beyond the intended use, or to interfere with the product in any other way.

ADDI-DATA shall not be liable for obvious printing and phrasing errors. In addition, ADDI DATA, if legally permissible, shall not be liable for personal injury or damage to materials caused by improper installation and/or commissioning of the product by the user or improper use, for example, if the product is operated despite faulty safety and protection devices, or if notes in the operating instructions regarding transport, storage, installation, commissioning, operation, thresholds, etc. are not taken into consideration. Liability is further excluded if the operator changes the product or the source code files without authorisation and/or if the operator is guilty of not monitoring the permanent operational capability of working parts and this has led to damage.

Copyright

This manual, which is intended for the operator and its staff only, is protected by copyright. Duplication of the information contained in the operating instructions and of any other product information, or disclosure of this information for use by third parties, is not permitted, unless this right has been granted by the product licence issued. Non-compliance with this could lead to civil and criminal proceedings.

ADDI-DATA software product licence

Please read this licence carefully before using the standard software. The customer is only granted the right to use this software if he/she agrees with the conditions of this licence.

The software must only be used to set up the ADDI-DATA products.

Reproduction of the software is forbidden (except for back-up and for exchange of faulty data carriers).

Disassembly, decompilation, decryption and reverse engineering of the software are forbidden. This

licence and the software may be transferred to a third party if this party has acquired a product by purchase, has agreed to all the conditions in this licence contract and the original owner does not keep any copies of the software.

Trademarks

- ADDI-DATA, APCI-1500, MSX-Box and MSX-E are registered trademarks of ADDI-DATA GmbH.
- Turbo Pascal, Delphi, Borland C, Borland C++ are registered trademarks of Borland Software Corporation.

- Microsoft .NET, Microsoft C, Visual C++, MS-DOS, Windows 95, Windows 98, Windows 2000, Windows NT, Windows EmbeddedNT, Windows XP, Windows Vista, Windows 7, Windows Server 2000, Windows Server 2003, Windows Embedded and Internet Explorer are registered trademarks of Microsoft Corporation.
- LabVIEW, LabWindows/CVI, DASyLab, DIAdem are registered trademarks of National Instruments Corporation.
- CompactPCI is a registered trademark of PCI Industrial Computer Manufacturers Group.
- VxWorks is a registered trademark of Wind River Systems, Inc.
- RTX is a registered trademark of IntervalZero.
- Mozilla Firefox is a registered trademark of Mozilla Foundation.
- SIMATIC S7 is a registered trademark of Siemens AG.

Warning

The following risks result from improper implementation and from use of the Ethernet system contrary to the regulations:



Personal injury



Damage to the Ethernet system, the PC and peripherals



Pollution of the environment

- Protect yourself, others and the environment!

- Read the safety precautions (yellow leaflet) carefully!

If this leaflet is not enclosed with the documentation, please contact us and ask for it.

- Observe the instructions of this manual!

Make sure that you do not forget or skip any step. We are not liable for damages resulting from a wrong use of the Ethernet system.

- Pay attention to the following symbols:



IMPORTANT!

Designates hints and other useful information.



WARNING!

Designates a possibly dangerous situation.

If the instructions are ignored, the Ethernet system, the PC and/or peripherals may be **destroyed**.

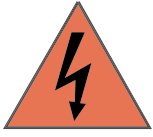

WARNING!

Designates a possibly dangerous situation.

If the instructions are ignored, the Ethernet system, the PC and/or peripherals may be **destroyed** and persons may be **endangered**.

Contents

Warning	4
Chapter overview	10
1 Definition of application, user, handling	11
1.1 Definition of application.....	11
1.1.1 Intended use.....	11
1.1.2 Usage restrictions.....	11
1.1.3 Limits of use	11
1.2 Safety precautions.....	11
1.2.1 Current sources	11
1.2.2 Degrees of protection	12
1.2.3 Cables	12
1.2.4 Housing.....	12
1.3 User	12
1.3.1 Qualification.....	12
1.3.2 Country-specific regulations	12
1.4 Handling of the Ethernet system.....	14
1.5 Questions and updates.....	14
2 Brief description	15
2.1 Functions and features.....	15
2.2 Block diagram	16
3 Temperature sensors	17
3.1 Thermocouples (TC).....	17
3.1.1 Types of thermocouples.....	18
3.1.2 Selection criteria for thermocouple types.....	22
3.2 Resistance temperature detectors (RTD)	22
3.2.1 Resistors depending on temperature (PTC)	22
3.2.2 Platinum resistors	22
3.2.3 Nickel resistors.....	24
4 Function description: Temperature sensor inputs	26
4.1 Pin assignment	26
4.1.1 TC inputs (MSX-E3211-TC)	26
4.1.2 RTD inputs (MSX-E3211-RTD)	28
4.2 Connection examples.....	29
4.2.1 TC sensors (MSX-E3211-TC).....	29
4.2.2 RTD sensors (MSX-E3211-RTD)	30
5 Web interface: Quick access to the MSX-E system	32

5.1	"I/O Configuration"	32
5.1.1	Menu item "Base configuration"	32
5.1.2	Menu item "Acquisition"	33
6	Acquisition modes	36
6.1	Auto-refresh mode	36
6.1.1	"Type of acquisition"	36
6.1.2	"Channels to be acquired"	36
6.1.3	"Average" (average value calculation).....	37
6.2	Sequence mode	38
6.2.1	"Type of acquisition"	38
6.2.2	"Channels to be acquired"	39
6.2.3	"Number of sequences to be acquired"	39
6.3	Common functions	41
6.3.1	Acquisition refresh time or delay.....	41
6.3.2	Trigger configuration	42
6.3.3	"Data frame" (additional data)	49
6.3.4	"Binary data frame packet structure" (packet format)	50
7	Technical data and limit values	51
7.1	Electromagnetic compatibility (EMC)	51
7.2	Mechanical structure	51
7.3	Versions	52
7.4	Limit values	52
7.4.1	Ethernet	53
7.4.2	Trigger input.....	53
7.4.3	Synchro input and output.....	54
7.4.4	Temperature sensor inputs.....	54
7.5	Sensor-specific properties.....	56
8	Appendix.....	57
8.1	Glossary	57
8.2	Index	60
9	Contact and support.....	61

Figures

Fig. 1-1: Correct handling.....	14
Fig. 2-1: MSX-E3211: Block diagram.....	16
Fig. 3-1: Thermocouple with reference junction.....	17
Fig. 3-2: Thermocouple types: Selection criteria.....	22
Fig. 4-1: Connection example: TC sensors	29
Fig. 4-2: Connection example: RTD sensors (2-wire circuit)	30
Fig. 4-3: Connection example: RTD sensors (3-wire circuit)	30
Fig. 4-4: Connection example: RTD sensors (4-wire circuit)	31
Fig. 5-1: Base configuration: Temperature channels.....	32
Fig. 5-2: Acquisition: Type of acquisition.....	33
Fig. 6-1: Acquisition: Type of acquisition.....	36
Fig. 6-2: Acquisition: Channels to be acquired.....	36
Fig. 6-3: Auto-refresh mode: "Average"	37
Fig. 6-4: Auto-refresh mode: Acquisition example	37
Fig. 6-5: Acquisition: Type of acquisition.....	38
Fig. 6-6: Acquisition: Channels to be acquired.....	39
Fig. 6-7: Acquisition: Number of sequences to be acquired.....	39
Fig. 6-8: Acquisition: Start/stop/monitor acquisition	40
Fig. 6-9: Auto-refresh mode: "Acquisition refresh time"	41
Fig. 6-10: Sequence mode: "Acquisition time"	41
Fig. 6-11: Acquisition: Trigger configuration.....	42
Fig. 6-12: Hardware trigger with "One-Shot" (a).....	44
Fig. 6-13: Hardware trigger with "One-Shot" (b).....	44
Fig. 6-14: Hardware trigger with "One-Shot" (c).....	45
Fig. 6-15: Hardware trigger with "One-Shot" (d)	46
Fig. 6-16: Hardware trigger with "Sequence" (a).....	46
Fig. 6-17: Hardware trigger with "Sequence" (b).....	47
Fig. 6-18: Hardware trigger with "Sequence" (c).....	48
Fig. 6-19: Acquisition: Data frame	49
Fig. 6-20: Acquisition: Binary data frame packet structure.....	50
Fig. 7-1: MSX-E3211: Dimensions	51
Fig. 7-2: MSX-E3211: View from above	52

Tables

Table 3-1: Thermocouples according to EN 60584-1 (IEC 584-1)..... 18

Table 3-2: Minimum and maximum thermocouple temperature 18

Table 3-3: Deviation limits for thermocouples according to EN 60 584 19

Table 3-4: Polynomial errors..... 21

Table 3-5: Accuracy classes of resistance temperature detectors 24

Table 4-1: Pin assignment: TC inputs 26

Table 4-2: Pin assignment: RTD inputs 28

Table 5-1: Auto-refresh mode: Data format 33

Table 5-2: Sequence mode: Data format 33

Table 7-1: MSX-E3211: Versions 52

Table 7-2: Real acquisition frequency..... 55

Table 7-3: RTD accuracy..... 55

Table 7-4: TC accuracy..... 56

Chapter overview

In this manual, you will find the following information:

Chapter	Content
1	Important information on the application, the user and on handling the MSX-E system as well as safety precautions
2	Brief description of the MSX-E system (functions, features, block diagram)
3	Information on TC and RTD temperature sensors
4	Function description (temperature sensor inputs) including pin assignments and connection examples
5	Description of the function-specific pages of the MSX-E web interface
6	Description of the acquisition modes (Auto-refresh and Sequence modes)
7	List of technical data and limit values of the MSX-E system
8	Appendix with glossary and index
9	Contact and support address

1 Definition of application, user, handling

1.1 Definition of application

1.1.1 Intended use

The Ethernet system **MSX-E3211** for the acquisition, processing and transferring of temperature sensor signals is intended for the connection to a network, which is used as electrical equipment for measurement, control and laboratory pursuant to the norm EN 61010-1 (IEC 61010-1).

1.1.2 Usage restrictions

The Ethernet system **MSX-E3211** must not be used as safety-related part (SRP).

The Ethernet system **MSX-E3211** must not be used for safety-related functions.

The Ethernet system **MSX-E3211** must not be used in potentially explosive atmospheres.

The Ethernet system **MSX-E3211** must not be used as electrical equipment according to the Low Voltage Directive 2006/95/EC.

1.1.3 Limits of use

All safety information and the instructions in the manuals must be followed to ensure proper intended use.

Uses of the Ethernet system beyond these specifications are considered as improper use.

The manufacturer is not liable for damages resulting from improper use.

The Ethernet system must remain in its anti-static packaging until it is installed.

Please do not delete the identification numbers of the Ethernet system or the warranty claim will be invalid.

1.2 Safety precautions

1.2.1 Current sources

All connected devices must be supplied from current sources that comply with SELV according to IEC 60950 or EN 60950; or PELV according to IEC 60204-1 or EN 60204-1.

1.2.2 Degrees of protection



IMPORTANT!

The protection according to the defined degree of protection (see Chapter 7.4) is only given if the openings are protected with adequate protection caps or connectors.

If you are not sure, please contact us:

Phone: +49 7229 1847-0

E-mail: info@addi-data.com

1.2.3 Cables

The cables must be installed safely against mechanical load.

1.2.4 Housing

The housing must not be opened. It may only be opened by persons who have been authorised by ADDI-DATA.

1.3 User

1.3.1 Qualification

Only persons trained in electronics are entitled to perform the following works:

- Installation
- Commissioning
- Use
- Maintenance.

1.3.2 Country-specific regulations

Do observe the country-specific regulations regarding

- the prevention of accidents
- electrical and mechanical installations

- Electromagnetic compatibility (EMC).

1.4 Handling of the Ethernet system

Fig. 1-1: Correct handling



- Hold the Ethernet system by the bottom and the grey sides.
- Do not hold the Ethernet system by the connectors!

1.5 Questions and updates

You can send us any questions by e-mail or call us:

E-mail: info@addi-data.com

Phone: +49 7229 1847-0.

Manual and software download from the Internet

The latest versions of the technical manual and the standard software for the Ethernet system **MSX-E3211** can be downloaded for free at:

www.addi-data.com



IMPORTANT!

Before using the Ethernet system or in case of malfunction during operation, check if there is an update (manual, driver, firmware) available on our website or contact us directly.

2 Brief description

In this chapter, the functions and features of the Ethernet system **MSX-E3211** are described in brief. Furthermore, you will find a general block diagram of the MSX-E system.

2.1 Functions and features

With the Ethernet system **MSX-E3211**, up to 16 thermocouples or resistance temperature detectors can be acquired.

For thermocouples, the cold junction compensation is made in the connector to reach a high degree of precision. For resistance temperature detectors, the current sources are integrated in the system and continuously monitored to obtain the highest possible precision.

Measurement sequences on multiple systems can be started simultaneously over an external trigger. The system can be configured over either the integrated web interface or SOAP commands. These interfaces also enable sensor data to be accessed.

Over an integrated Ethernet switch, the system can be cascaded with other MSX-E systems. This also applies to the voltage supply and the trigger/synchro line, which facilitates wiring between the single systems.

The Ethernet system is mounted in a robust EMC-protected metal housing, which complies with the degree of protection IP 65. In this way, the Ethernet system is able to cope with daily stresses and strains such as current peaks, vibrations, dirt or extreme temperatures. Moreover, it can be used in the extended operating temperature range from -40 °C to +85 °C and is equipped with numerous protective circuits. Error diagnoses are quickly identified by means of the "Status" LED display.

The electronics are no longer in the computer itself but in an external housing connected to the computer via Ethernet. As the Ethernet system is attached directly to the signal generator (measuring point), the measurements can no longer be affected by long cables. The length of the (Ethernet) connection cable from the Ethernet system to the computer may be up to 150 m. The system must be supplied with external voltage (24 V).

Features:

- 8 or 16 differential inputs for thermocouples (TC) or resistance temperature detectors (RTD)
- TC sensor types: B, E, J, K, N, R, S, T; RTD sensor types: platinum (e. g. Pt100), nickel (e. g. Ni100)
- Internal current sources for RTD sensors or for cold junction compensation with thermocouples
- Sampling frequency: can be configured in groups in the range from 2.5 Hz to 1 kHz

- Acquisition: can be controlled by means of an external trigger (digital 24 V trigger input)
- Web interface to configure, control and monitor the acquisition
- Data access via SOAP or Modbus (always TCP or UDP)
- Optical isolation
- Degree of protection: IP 65
- Cascadable; synchronisation in the μ s range
- Extended operating temperature range from $-40\text{ }^{\circ}\text{C}$ to $+85\text{ }^{\circ}\text{C}$

2.2 Block diagram

Fig. 2-1: MSX-E3211: Block diagram

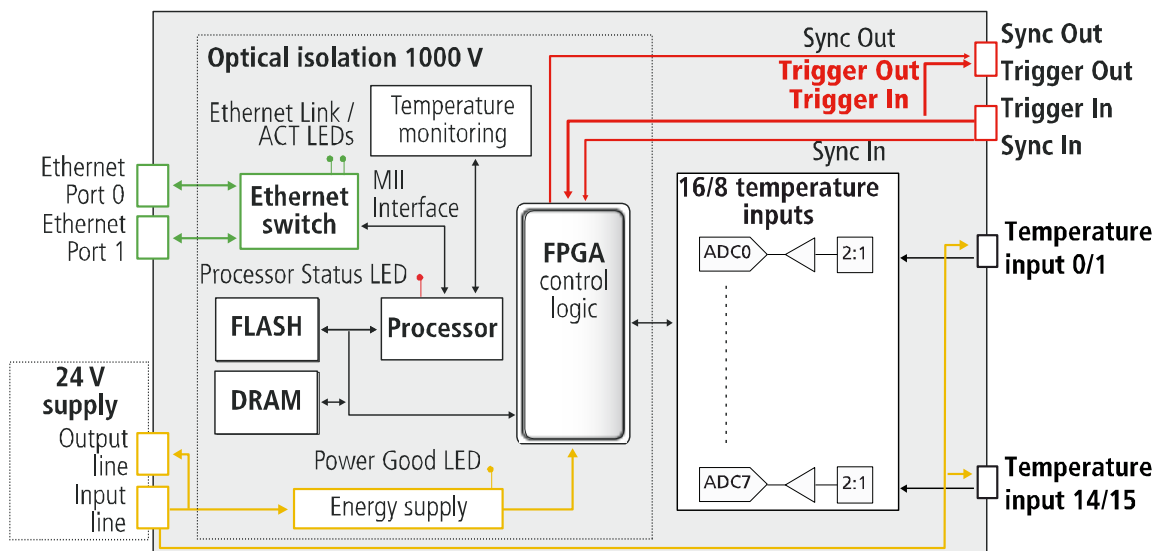

3 Temperature sensors

In this chapter, the properties of the different temperature sensors are described in more detail. This should help you to find the right temperature sensor for your measuring system and to identify and prevent possible measuring errors in advance.

3.1 Thermocouples (TC)

Thermocouples consist of two different metallic conductors (metals A and B) that are welded with each other at one end.

If at the junction of the two conductors the temperature differs from the ambient temperature, a voltage is generated. The value of this voltage depends on the temperature difference and the materials used. The ratio of the generated voltage to the temperature difference is approximately proportional. In order to linearise this ratio, polynomials are used which correct the measurement values.

If a thermocouple is connected to a measuring system, another thermocouple is produced at this junction, that is between the two thermocouple metals and the metal of the connector at the measuring system. To correct the measuring error occurring at this junction through the additional thermocouple, the temperature at this junction (reference temperature) has to be known. For this, it is acquired by a Pt1000 sensor and used to calculate the temperature at the measuring point.

Strictly speaking, there are different metal combinations at each junction between connectors, conductors and components that can take effect like a thermocouple. However, measuring errors come to an insignificant extent, because these are pairs of identical metals.

Fig. 3-1: Thermocouple with reference junction

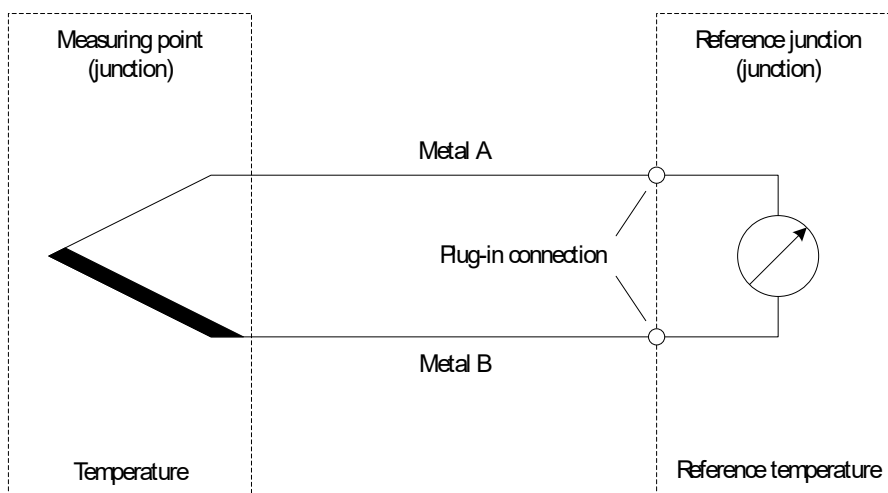

**IMPORTANT!**

Further junctions between a thermocouple and the **MSX-E3211-TC** may produce additional thermoelectric effects which lead to an incorrect measurement result. Therefore, you should try to avoid further junctions (e. g. through extension cables)!

3.1.1 Types of thermocouples

Table 3-1: Thermocouples according to EN 60584-1 (IEC 584-1)

Type designation	Positive leg: material	Colour code (positive pole)	Negative leg: material	Colour code (negative pole)
B	platinum 30% rhodium	grey	platinum 6% rhodium	white
E	nickel-chromium	purple	copper-nickel	white
J	iron	black	copper-nickel	white
K	nickel-chromium	green	nickel-aluminium	white
N	nickel-chromium-silicium	pink	nickel-silicium	white
R	platinum 13% rhodium	orange	platinum	white
S	platinum 10% rhodium	orange	platinum	white
T	copper	brown	copper-nickel	white

Table 3-2: Minimum and maximum thermocouple temperature

Type	Material	Colour code	Minimum	Maximum	Defined up
------	----------	-------------	---------	---------	------------

designation		(positive pole)	temperature (°C)	temperature (°C)	to (°C)
B	Pt30Rh-Pt6Rh	grey	0	1700	1820
E	NiCr-CuNi	purple	-270	900	1000
J	Fe-CuNi	black	-210	750	1200
K	NiCr-Ni	green	-270	1200	1370
N	NiCrSi-NiSi	pink	-270	1200	1300
R	Pt13Rh-Pt	orange	-50	1600	1760
S	Pt10Rh-Pt	orange	-50	1600	1540
T	Cu-CuNi	brown	-270	350	400

With thermocouples, the temperature/voltage ratio is approximated by means of a polynomial. This approximation leads to additional deviation errors.

Table 3-3: Deviation limits for thermocouples according to EN 60 584

Type designation	Tolerance class	Temperature range (°C)	Tolerance
B	Class 1	600 to 1700	$\pm 0,0025 \cdot t$ oder $\pm 1,5 \text{ °C}$
	Class 2	600 to 1700	$\pm 0,005 \cdot t$ oder $\pm 4 \text{ °C}$
	Class 3		
E	Class 1	-40 to +900	$\pm 0,004 \cdot t$ oder $\pm 1,5 \text{ °C}$
	Class 2	-40 to +900	$\pm 0,0075 \cdot t$ oder $\pm 2,5 \text{ °C}$
	Class 3	-200 to +40	$\pm 0,0015 \cdot t$ oder $\pm 2,5 \text{ °C}$
J	Class 1	-40 to +750	$\pm 0,004 \cdot t$ oder $\pm 1,5 \text{ °C}$

	Class 2	-40 to +750	$\pm 0,0075 \cdot t$ oder $\pm 2,5 \text{ }^\circ\text{C}$
	Class 3		
K, N	Class 1	-40 to +1000	$\pm 0,004 \cdot t$ oder $\pm 1,5 \text{ }^\circ\text{C}$
	Class 2	-40 to +1200	$\pm 0,0075 \cdot t$ oder $\pm 2,5 \text{ }^\circ\text{C}$
	Class 3	-200 to +40	$\pm 0,0015 \cdot t$ oder $\pm 2,5 \text{ }^\circ\text{C}$
R, S	Class 1	0 to 1600	$\pm [1 + 0,003 \cdot (t - 1100 \text{ }^\circ\text{C})]$ oder $\pm 1 \text{ }^\circ\text{C}$
	Class 2	0 to 1600	$\pm 0,0025 \cdot t$ oder $\pm 1,5 \text{ }^\circ\text{C}$
	Class 3		
T	Class 1	0 to 350	$\pm 0,004 \cdot t$ oder $\pm 0,5 \text{ }^\circ\text{C}$
	Class 2	-40 to +350	$\pm 0,0075 \cdot t$ oder $\pm 1 \text{ }^\circ\text{C}$
	Class 3	-200 to +40	$\pm 0,0015 \cdot t$ oder $\pm 1 \text{ }^\circ\text{C}$

Table 3-4: Polynomial errors

Type designation	Temperature range (°C)	Temperature range (μV)	Polynomial error (°C)	
			min	max
B	250 to 700	291 to 2431	-0,02	0,026
	700 to 1820	2431 to 13820	-0,007	0,012
E	-200 to 0	-8825 to 0	-0,01	0,022
	0 to 1000	0 to 76373	-0,012	0,016
J	-210 to 0	-8095 to 0	-0,048	0,028
	0 to 760	0 to 42919	-0,035	0,037
	760 to 1200	42919 to 69553	-0,037	0,024
K	-200 to 0	-5891 to 0	-0,018	0,041
	0 to 500	0 to 20644	-0,047	0,033
	500 to 1372	20644 to 54886	-0,046	0,054
N	-200 to 0	-3990 to 0	-0,013	0,027
	0 to 600	0 to 20613	-0,016	0,027
	600 to 1300	20613 to 47513	-0,039	0,021
R	-50 to +250	-226 to +1923	-0,011	0,018
	250 to 1064	1923 to 11361	-0,003	0,005
	1064 to 1664,5	11361 to 19739	0,000	0,001
	1664,5 to 1768,1	19739 to 21103	0,001	0,001
S	-50 to +250	-235 to +1874	-0,011	0,02
	250 to 1064	1874 to 10332	-0,009	0,006
	1064 to 1664,5	10332 to 17536	0,000	0,000
	1664,5 to 1768,1	17536 to 18694	-0,002	0,001
T	-200 to 0	-5603 to 0	-0,017	0,038
	0 to 400	0 to 20872	-0,025	0,025

3.1.2 Selection criteria for thermocouple types

Fig. 3-2: Thermocouple types: Selection criteria

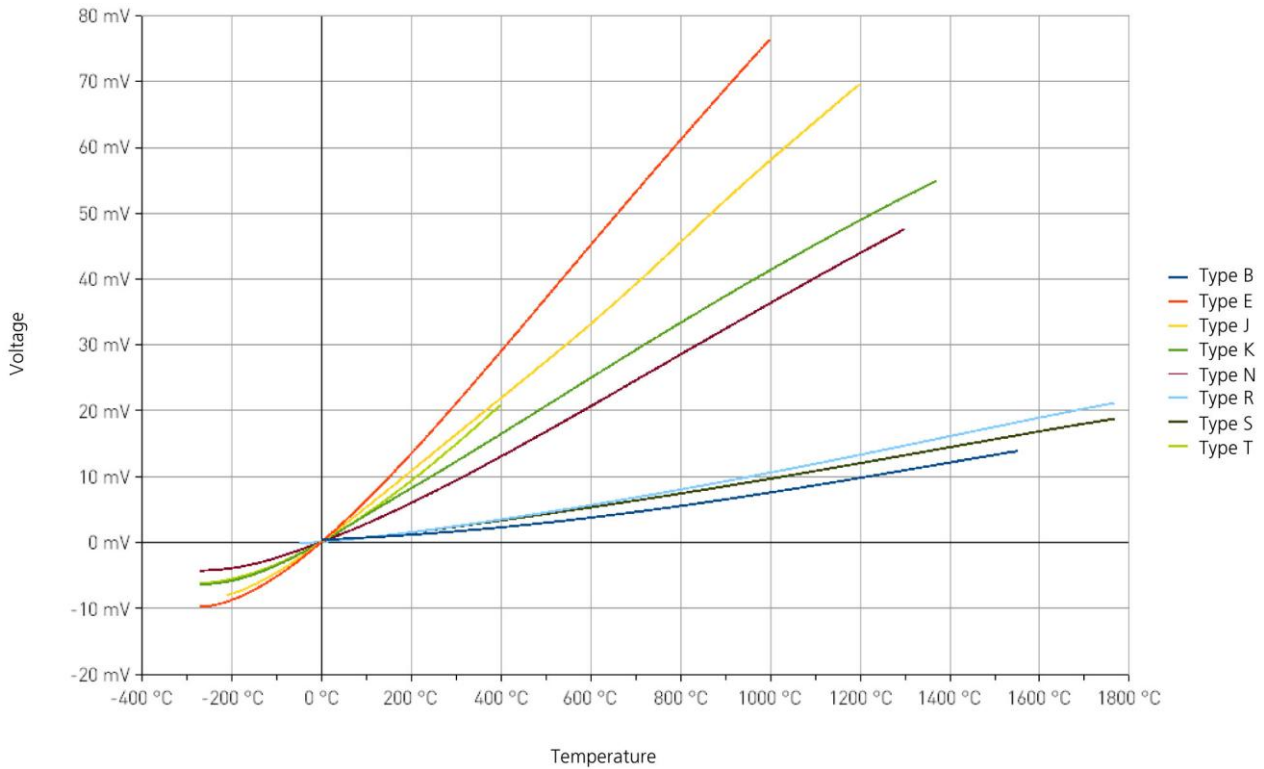

3.2 Resistance temperature detectors (RTD)

3.2.1 Resistors depending on temperature (PTC)

The electrical conductivity of a metal depends on the mobility of its conduction electrons. These move to the positive pole when a voltage is applied to the ends of the metal. Since with rising temperature the atoms of the metal lattice oscillate more intensely about their rest position, the electron movement is increasingly hindered. The electrical resistance in the metal grows and thus directly depends on the temperature. For this reason, this is called a positive temperature coefficient, i. e. a PTC resistor.

3.2.2 Platinum resistors

In industrial measurement, platinum RTDs are generally used, since this material offers advantages such as high chemical resistance, easy workability and good reproducibility of the electrical properties. The latter are defined in the norm EN 60 751 (IEC 751) so that platinum resistors are universally interchangeable.

The EN norm defines, for example, the variation of resistance with temperature, the nominal value, the permissible deviation limits as well as the temperature range.

For the temperature/resistance ratio, which is not directly proportional, the temperature range from -200 °C to 0 °C is covered by a third-order polynomial:

$$R(t) = R_0 (1 + A \cdot t + B \cdot t^2 + C \cdot [t - 100^\circ\text{C}] \cdot t^3)$$

A second-order polynomial covers the temperature range from 0 °C to 850 °C:

$$R(t) = R_0 (1 + A \cdot t + B \cdot t^2)$$

The coefficients are calculated as follows:

$$\begin{aligned} A &= 3,9083 \cdot 10^{-3} \cdot ^\circ\text{C}^{-1} \\ B &= -5,775 \cdot 10^{-7} \cdot ^\circ\text{C}^{-2} \\ C &= -4,183 \cdot 10^{-12} \cdot ^\circ\text{C}^{-4} \end{aligned}$$

The nominal value R_0 is the resistance at 0 °C. For a Pt100 resistor, a nominal value of 100 Ω is defined by the EN norm.

From the temperature sensor resistance, you can calculate the respective temperature.

In terms of permissible temperatures deviating from actual sensor temperatures, the EN norm distinguishes between the following accuracy classes. Class A only applies to thermometers with 3-wire and 4-wire circuit connections.

Table 3-5: Accuracy classes of resistance temperature detectors

Tolerance class	Applicable range (°C)		Deviation limit* (°C)
	Wire-wound resistors	Film resistors	
AA	-50 to +250	0 to +150	$\pm (0,1 + 0,0017 \cdot t)$
A	-100 to +450	-30 to +300	$\pm (0,15 + 0,002 \cdot t)$
B	-196 to +600	-50 to +500	$\pm (0,3 + 0,005 \cdot t)$
C	-196 to +600	-50 to +600	$\pm (0,6 + 0,01 \cdot t)$

* t = Temperature in °C (without sign)

3.2.3 Nickel resistors

Nickel is another resistance material, but much more rarely used as a resistance temperature detector than platinum. It is much cheaper than platinum; however, due to its low chemical resistance, the measurement range only extends from -60 °C to +250 °C.

For the variation of resistance with temperature, the following formula applies:

$$R(t) = R_0 (1 + A \cdot t + B \cdot t^2 + C \cdot t^4 + D \cdot t^6)$$

Calculating the coefficients:

$$A = 0,5485 \cdot 10^{-2} \cdot \text{°C}^{-1}$$

$$B = 0,665 \cdot 10^{-5} \cdot \text{°C}^{-2}$$

$$C = 2,805 \cdot 10^{-11} \cdot \text{°C}^{-4}$$

$$D = 2,111 \cdot 10^{-17} \cdot \text{°C}^{-6}$$

The nominal value R_0 at 0 °C is 100 Ω.

Deviations from actual sensor temperatures are defined as follows:

0 °C to 250 °C:

$$\Delta t = \pm (0,4 + 0,007 \cdot t)$$

-60 °C to 0 °C:

$$\Delta t = \pm (0,4 + 0,028 \cdot t)$$

t = Temperature in °C (without sign)

Defining these accuracy classes allows for replacing Ni100 sensors by one another without recalibration.

4 Function description: Temperature sensor inputs

The Ethernet system **MSX-E3211** has 16 differential inputs for thermocouples or resistance temperature detectors.

4.1 Pin assignment

To each M12 female connector, up to two temperature sensors can be connected.

The differential sensor input 1 or 2 consists of TCx+ and TCx- or RTDx+ and RTDx-. One input channel consists of sensor input x+ and x- signals, current source x and one GND line. EXC stands for one of the two current sources 1 and 2 (only with RTD).

4.1.1 TC inputs (MSX-E3211-TC)

Table 4-1: Pin assignment: TC inputs

Pin No.	Female connector, 8-pin, M12	Cable (black)
		Lead colour
1	TC1+	white
2	TC1-	brown
3	CJC1	green
4	GND	yellow
5	TC2+	grey
6	TC2-	pink
7	CJC2	blue
8	GND	red

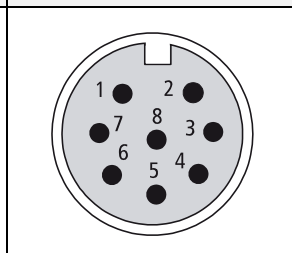

TC = Thermocouple ; CJC = Cold junction compensation

4.1.2 RTD inputs (MSX-E3211-RTD)

Table 4-2: Pin assignment: RTD inputs

Pin No.	Female connector, 8-pin, M12	Cable (black)
		Lead colour
1	RTD1+	white
2	RTD1-	brown
3	EXC1	green
4	GND	yellow
5	RTD2+	grey
6	RTD2-	pink
7	EXC2	blue
8	GND	red

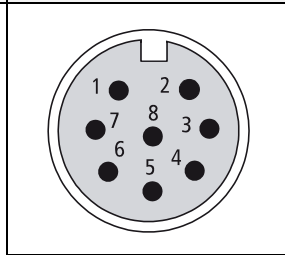

RTD = Resistance temperature detector

EXC = Current source (excitation)

4.2 Connection examples

4.2.1 TC sensors (MSX-E3211-TC)

Fig. 4-1: Connection example: TC sensors

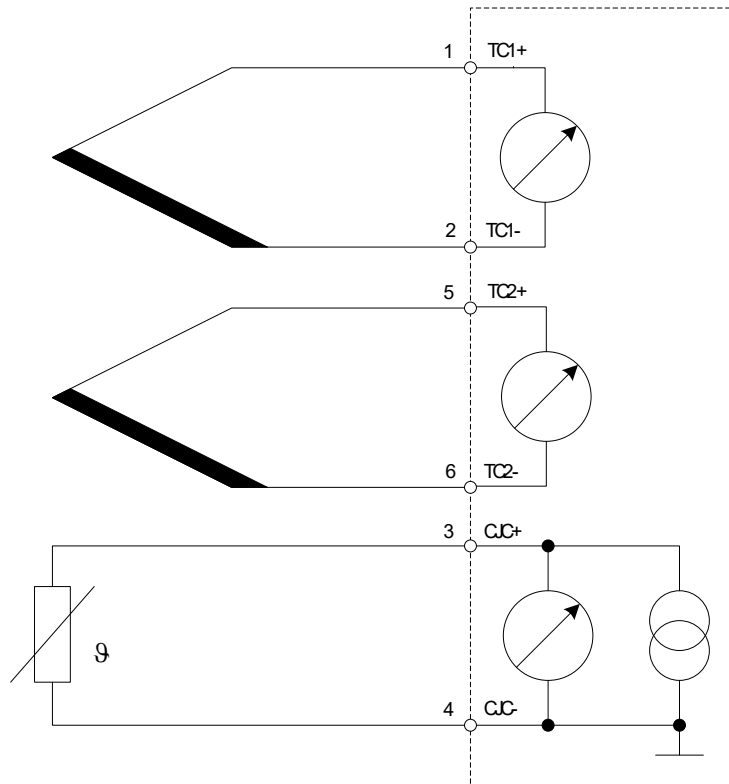

4.2.2 RTD sensors (MSX-E3211-RTD)

a) 2-wire circuit

Fig. 4-2: Connection example: RTD sensors (2-wire circuit)

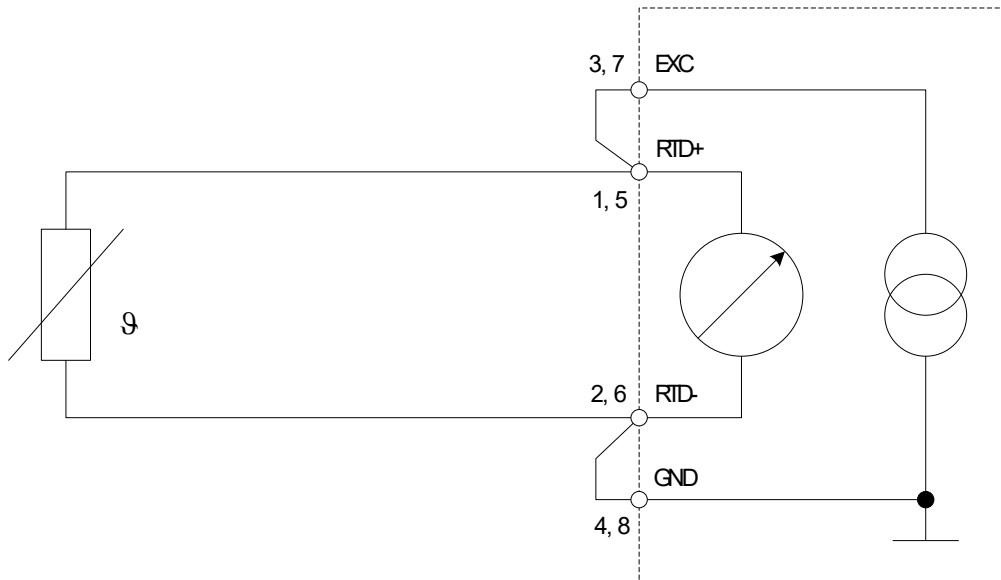

b) 3-wire circuit

Fig. 4-3: Connection example: RTD sensors (3-wire circuit)

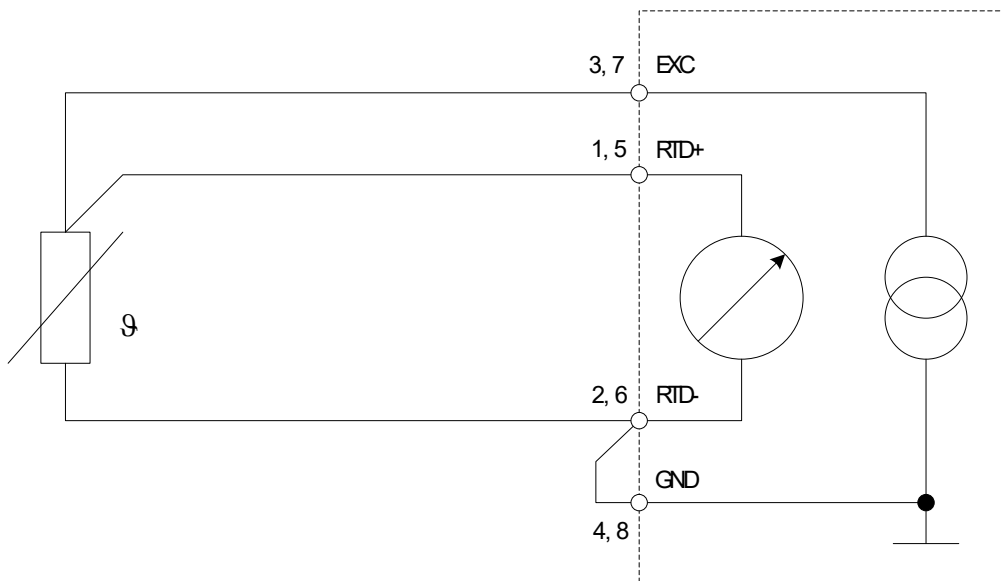

c) 4-wire circuit

Fig. 4-4: Connection example: RTD sensors (4-wire circuit)

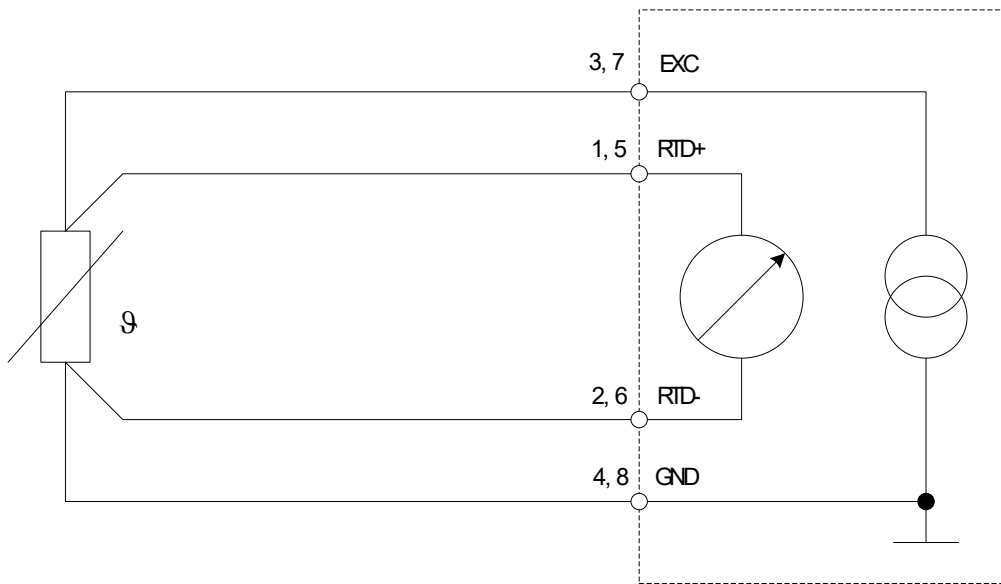

5 Web interface: Quick access to the MSX-E system

5.1 “I/O Configuration”

In this manual, the function-specific pages of the **MSX-E3211** web interface, which are located under the menu item “I/O Configuration”, are described.

For further information on the MSX-E web interface, please refer to the general manual of the MSX-E systems (see PDF link).

5.1.1 Menu item “Base configuration”

Fig. 5-1: Base configuration: Temperature channels

Temperature channel(s)

Get the input type RTD/TC:
Get/set the temperature sensor type:

- For TC: B / E / J / K / N / R / S / T
- For RTD : Pt10 / Pt20 / Pt50 / Pt100 / Pt200 / Pt500 / Pt1000 / Pt2000 / Ni10 / Ni20 / Ni50 / Ni100 / Ni200 / Ni500 / Ni1000 / Ni2000

Get/set the sampling rate:

- 5 Hz / 10 Hz / 20 Hz / 40 Hz / 80 Hz / 160 Hz / 320 Hz / 640 Hz / 1000 Hz / 2000 Hz

Sampling rate note:

- If one channel per connector is used, the maximum acquisition frequency is **sampling rate / 2**.
- If two channels per connector are used, then the maximum acquisition frequency is **sampling rate / 3**

	Channel 0	Channel 1	Channel 2	Channel 3	Channel 4	Channel 5	Channel 6	Channel 7
Class	RTD	RTD	RTD	RTD	RTD	RTD	RTD	RTD
Type	Pt100	Pt100	Pt100	Pt100	Pt100	Pt100	Pt100	Pt100
Sampling rate	160Hz		160Hz		160Hz		160Hz	
	Max frequency for 1 channel:	80Hz (12.5ms)	Max frequency for 1 channel:	80Hz (12.5ms)	Max frequency for 1 channel:	80Hz (12.5ms)	Max frequency for 1 channel:	80Hz (12.5ms)
	Max frequency for 2 channels:	53.333Hz (18.75ms)	Max frequency for 2 channels:	53.333Hz (18.75ms)	Max frequency for 2 channels:	53.333Hz (18.75ms)	Max frequency for 2 channels:	53.333Hz (18.75ms)
Line diagnosis	RTD channel line open	RTD channel line open	OK	OK	RTD channel line open	RTD channel line open	RTD channel line open	RTD channel line open

On this page, you can configure the temperature inputs by defining the TC or RTD sensor type for each channel as well as by selecting the respective sampling frequency.

If a short-circuit or line break occurs, this will be specified in the table above under “Line diagnosis”.

5.1.2 Menu item “Acquisition”

Fig. 5-2: Acquisition: Type of acquisition

Type of acquisition

None
 Auto-refresh
 Sequence

For the acquisition, the Auto-refresh mode and the Sequence mode are available. A detailed description of these modes can be found in Chapter 6 of this manual.

Data format

In Auto-refresh mode, the following data format applies:

Table 5-1: Auto-refresh mode: Data format

tv_sec	tv_usec	Auto-refresh counter	Hardware trigger	Auto-refresh data
4 bytes	4 bytes	4 bytes	4 bytes	4 bytes x amount of data
optional (if data format has time stamp)	optional (if data format has time stamp)	optional (if data format has Auto-refresh counter)	optional (if data format has hardware trigger)	The amount of data depends on the setting.

In Sequence mode, the data format is as follows:

Table 5-2: Sequence mode: Data format

tv_sec	tv_usec	Sequence counter	Hardware trigger	Sequence data
4 bytes	4 bytes	4 bytes	4 bytes	4 bytes x amount of data
optional (if data format has time stamp)	optional (if data format has time stamp)	optional (if data format has Sequence counter)	optional (if data format has hardware trigger)	The amount of data depends on the Sequence channel

time stamp)	time stamp)			list.
-------------	-------------	--	--	-------

To both modes applies:

Data format = without conversion into an analog value

Data x	32-bit digital value
--------	----------------------



IMPORTANT!

Please note that the digital value is an internal value of the A/D converter and thus not suitable for temperature or resistance value calculation. Please only use the analog value for this purpose!

Data format = with conversion into an analog value

Data x	32-bit floating point value (analog value) in V/A
--------	--

The **MSX-E3211** converts the temperature value immediately to the unit degree Celsius (°C) while converting it into an analog value.

For more information on the data format, see Chapter 6.3.4.

6 Acquisition modes

This chapter exemplifies how to configure and start an acquisition via the web interface of the Ethernet system **MSX-E3211**. Moreover, you can use Modbus or SOAP functions (see MSX-E CD or driver download on the ADDI-DATA website) to perform these steps.

6.1 Auto-refresh mode

In Auto-refresh mode, one or more channels can be acquired. It is possible to start the acquisition by means of a trigger. Directly on the MSX-E system, an average value can be calculated.

- On the web interface, from the menu on the left, under "I/O Configuration", select the menu item "Acquisition".

6.1.1 "Type of acquisition"

Fig. 6-1: Acquisition: Type of acquisition

Type of acquisition

None
 Auto-refresh
 Sequence

- In the section "Type of acquisition", select the acquisition mode "Auto-refresh".

6.1.2 "Channels to be acquired"

Fig. 6-2: Acquisition: Channels to be acquired

Channels to be acquired

Please select the channels you want to acquire.

Channel	Channel	Channel	Channel	Channel	Channel	Channel	Channel	Channel	Channel	Channel	Channel	Channel	Channel	Channel	Channel
0	1	2	3	4	5	6	7	8	9	10	11	12	13	14	15
<input type="checkbox"/>	<input type="checkbox"/>	<input type="checkbox"/>	<input type="checkbox"/>	<input type="checkbox"/>	<input type="checkbox"/>	<input type="checkbox"/>	<input type="checkbox"/>	<input type="checkbox"/>	<input type="checkbox"/>	<input type="checkbox"/>	<input type="checkbox"/>	<input type="checkbox"/>	<input type="checkbox"/>	<input type="checkbox"/>	<input type="checkbox"/>

- In the section "Channels to be acquired", select the channels you want to acquire.

6.1.3 “Average” (average value calculation)

Fig. 6-3: Auto-refresh mode: “Average”

Average

If this option is enabled each channel is acquired x times (x= Number of acquisitions > 1). Afterwards, the average value for each channel is computed.

Number of acquisitions 10

Acquisition refresh time: 1000(refresh time) * 10(average value) = 10000 millisecond

The MSX-E system is capable of calculating an average value for each channel. In the field “Number of acquisitions”, you have to enter the number of acquisitions after which this value should be calculated.

Example

The MSX-E system acquires channels 1 to 8. “Number of acquisitions” contains the value 10. This means that ten sequences run down, with each sequence consisting of eight channels to be acquired simultaneously.

Fig. 6-4: Auto-refresh mode: Acquisition example

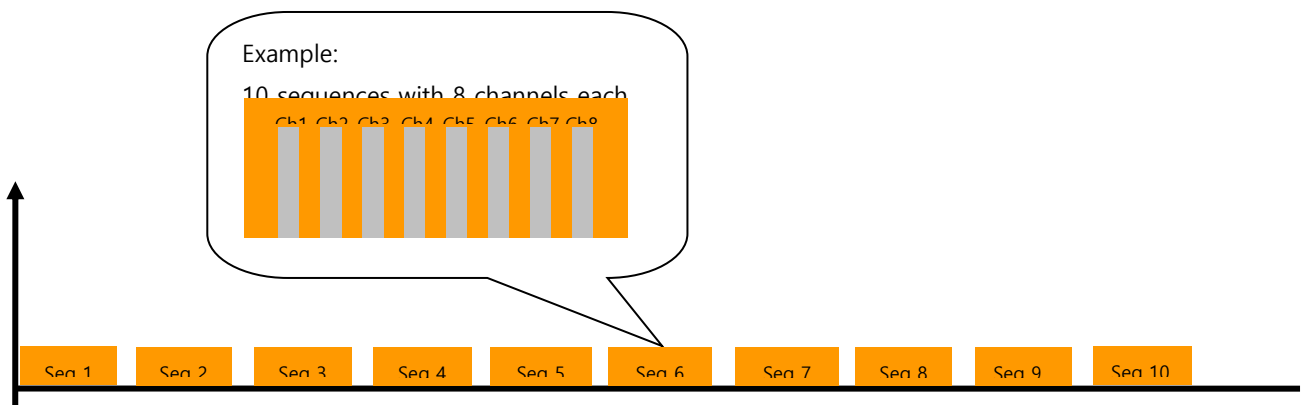

After these ten sequences have run down, the MSX-E system performs the following calculation:

Average value of channel 1
 = (sequence 1, value of channel 1 + sequence 2, value of channel 1 + ... + sequence 10, value of channel 1) / 10

Average value of channel 2
 = (sequence 1, value of channel 2 + sequence 2, value of channel 2 + ... + sequence 10, value of channel 2) / 10

```

10
...
Average value of channel 8
= (sequence 1, value of channel 8 + sequence 2, value of channel 8 + ... + sequence 10, value of channel 8) /
10
    
```

The network client will not receive ten data packets, with eight values in each packet, but only one data packet containing the average values from channels 1 to 8.

6.2 Sequence mode

The Sequence mode enables you to acquire one or more channels. The acquisition can be started by a trigger. There is a definable delay between the individual sequences.

- On the web interface, from the menu on the left, under "I/O Configuration", select the menu item "Acquisition".

6.2.1 "Type of acquisition"

Fig. 6-5: Acquisition: Type of acquisition

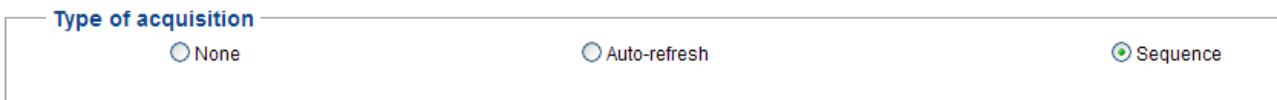

- In the section "Type of acquisition", select the acquisition mode "Sequence".

6.2.2 “Channels to be acquired”

Fig. 6-6: Acquisition: Channels to be acquired

Channels to be acquired

Please select the channels you want to acquire.

Notes

- A void channel entry in a **Value** field means that from this field, no channel will be acquired.
- During one sequence, a channel cannot be acquired several times.

Value 0	Value 1	Value 2	Value 3	Value 4	Value 5	Value 6	Value 7
<input type="text" value=""/>	<input type="text" value=""/>	<input type="text" value=""/>	<input type="text" value=""/>	<input type="text" value=""/>	<input type="text" value=""/>	<input type="text" value=""/>	<input type="text" value=""/>
Value 8	Value 9	Value 10	Value 11	Value 12	Value 13	Value 14	Value 15
<input type="text" value=""/>	<input type="text" value=""/>	<input type="text" value=""/>	<input type="text" value=""/>	<input type="text" value=""/>	<input type="text" value=""/>	<input type="text" value=""/>	<input type="text" value=""/>

Number of channels per sequence: 0

■ In the section “Channels to be acquired”, select the channels you want to acquire.

You can define the order of the channels. Each channel can be acquired only once per sequence.

6.2.3 “Number of sequences to be acquired”

Fig. 6-7: Acquisition: Number of sequences to be acquired

Number of sequences to be acquired

In the field **Number of sequences**, you can define the number of sequences that should be acquired.

- Enter 0 for a **continuous acquisition**.
- The maximum value for this field is $2^{32}-1$ (4294967295)

In the field **Number of data frames**, you determine the number of sequences (1 to 4096) that should be acquired before the MSX-E system sends the data to the network via the data server.

Number of sequences	<input type="text" value="0"/>
Number of data frames	<input type="text" value="1"/>

In the field “Number of sequences”, you enter the number of sequences to be acquired. If this value is 0, the acquisition is continuous. If it is a value between 1 and 4294967295, the number of sequences is predefined.

Example

To acquire four sequences, the field “Number of sequences” must contain the value 4. As a result, when you start (“Start” button in the section “Start/stop/monitor acquisition”, see the following figure) four sequences are acquired.

Fig. 6-8: Acquisition: Start/stop/monitor acquisition

Start/stop/monitor acquisition

Notes:

- The **Start** button first stops any acquisition running and then starts the Sequence acquisition.
- The **Stop** button stops any acquisition running.
- The **Monitor** button uses the current configuration for the acquisition and monitors the current values on the MSX-E website.
- The **Start/Monitor** button uses the selected configuration to start an Sequence acquisition and to display the acquired values.

Number of data packets to be acquired
Number of packets you want to retrieve (a maximum of 100,000) and display

Export data to CSV

[Start](#) [Stop](#) [Monitor](#) [Start/Monitor](#)

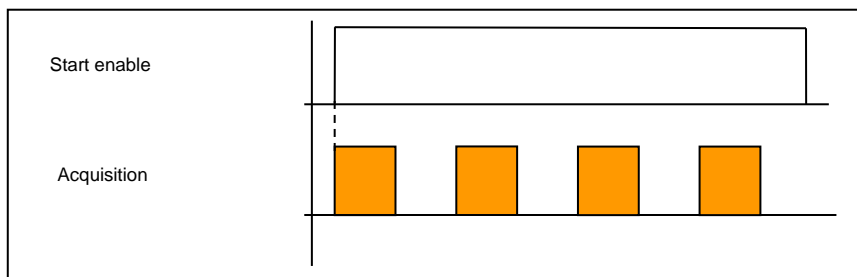

In the field "Number of data frames", you define the maximum number of sequences that have to be acquired before the measurement values are sent to the target system. If the MSX-E system does not have sufficient memory to store the required number of sequences, the measurement values are sent earlier, that is, before the maximum number of sequences to be acquired is reached. This helps to reduce the network traffic load and the CPU resources of the MSX-E systems.

Example

When you start (see Fig. 6-8), the acquisition begins. If two sequences are acquired, the measurement values are sent to the client.

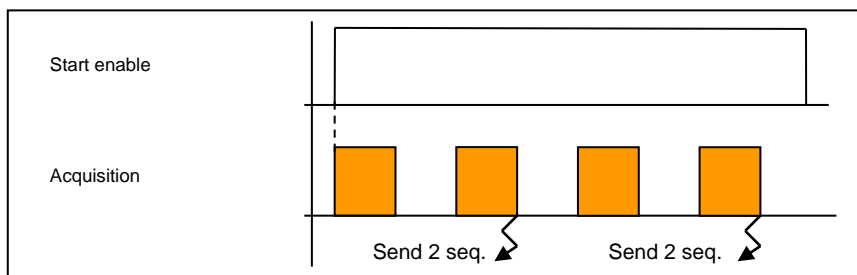

6.3 Common functions

The following functions are available both in Auto-refresh mode and in Sequence mode.

6.3.1 Acquisition refresh time or delay

Fig. 6-9: Auto-refresh mode: “Acquisition refresh time”

Acquisition refresh time

In the **Refresh time** field, you can set the Auto-refresh time for all channels.

From the **Refresh time unit** list, you can select the desired time unit (microsecond, millisecond or second)

Depending on the **Refresh time unit** the range allowed for the **Refresh time** varies:

Refresh time unit	Refresh time
Microsecond	1000 to 65535
Millisecond	1 to 65535
Second	1 to 65535

Refresh time

Refresh time unit

In Auto-refresh mode, the time between the refreshing of the single sequences is called acquisition refresh time.

Fig. 6-10: Sequence mode: “Acquisition time”

Acquisition time

In the **Acquisition time** field, you set the Sequence acquisition time for all channels.

From the **Acquisition time unit** list, you select the desired time unit (microsecond, millisecond or second).

Depending on the **Acquisition time unit** the range allowed for the **Acquisition time** varies:

Acquisition unit	Acquisition time
Microsecond	1000 to 65535
Millisecond	1 to 65535
Second	1 to 65535

Acquisition time

Acquisition time unit

Receive all data: $1000 \text{ (acquisition time)} * 1 \text{ (transfer size)} = 1000 \text{ microsecond}$

In Sequence mode, the delay is the time between the acquisitions of single sequences.

As the unit of this acquisition refresh time or delay, microseconds, milliseconds or seconds can be defined. The range in which this time can lie is based on the unit that is selected:

<p>Microseconds: 1000 to 65535</p> <p>Milliseconds: 1 to 65535</p> <p>Seconds: 1 to 65535</p>
--

6.3.2 Trigger configuration

The acquisition can be started by an external signal.

The synchro trigger configuration has to be set both on the master's and slave's web interface.

Fig. 6-11: Acquisition: Trigger configuration

Trigger source	Not used
Trigger mode	One-shot
Hardware trigger active edge	Rising
Hardware trigger count Number of trigger events before the acquisition starts	1
Number of sequences per trigger Number of sequences to be acquired after each trigger event	1

- **Trigger source:** Available trigger types are hardware trigger and synchro trigger.
- **Trigger mode:** If the trigger mode "One-shot" is selected, only one acquisition starts after a trigger. If the option "Sequence" (= "multi-shot") is activated, a defined number of acquisitions starts (see field "Number of sequences per trigger").
- **Hardware trigger active edge:** Here, the type of edge is defined in case of which the MSX-E system identifies a trigger.
- **Hardware trigger count:** This field defines the number of edges after which an acquisition is started.
- **Number of sequences per trigger:** In the trigger mode "Sequence" (see field "Trigger mode"), the number of sequences that are acquired after a trigger is defined. This value must be between 1 and 65535.

The following pages contain examples of the hardware trigger.

For further information on the hardware or synchro trigger, please refer to the general manual of the MSX-E systems (see PDF link).

1) Examples of edges

a) **Rising:** Rising edge

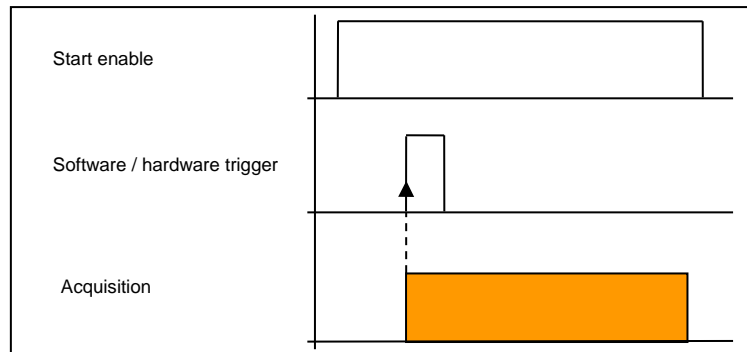

b) **Falling:** Falling edge

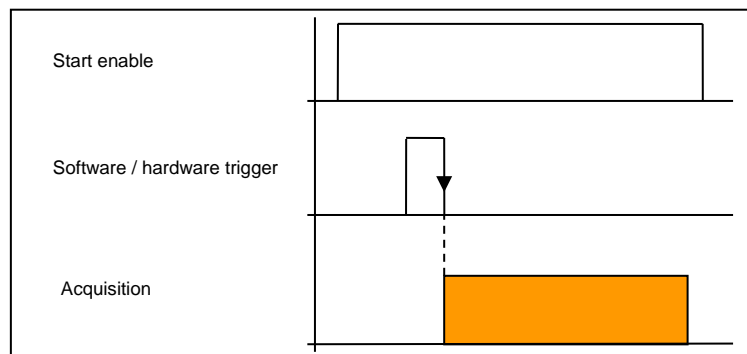

c) **Both:** Rising and falling edges

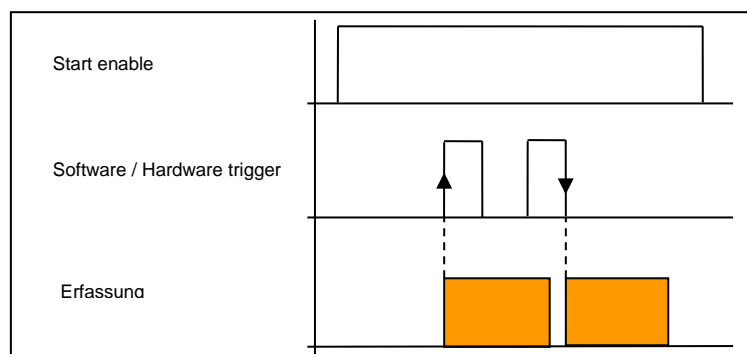

2) Examples of hardware triggers with “One-shot”

a) To start the acquisition once only after three rising edges, you can use the following parameters:

Fig. 6-12: Hardware trigger with “One-Shot” (a)

Trigger source	Hardware trigger
Trigger mode	One-shot
Hardware trigger active edge	Rising
Hardware trigger count Number of trigger events before the acquisition starts.	3
Number of sequences per trigger Number of sequences to be acquired after each trigger event	1

After the start (see Fig. 6-8), the MSX-E system waits for three rising hardware edges. Once the three edges have been identified, the acquisition starts.

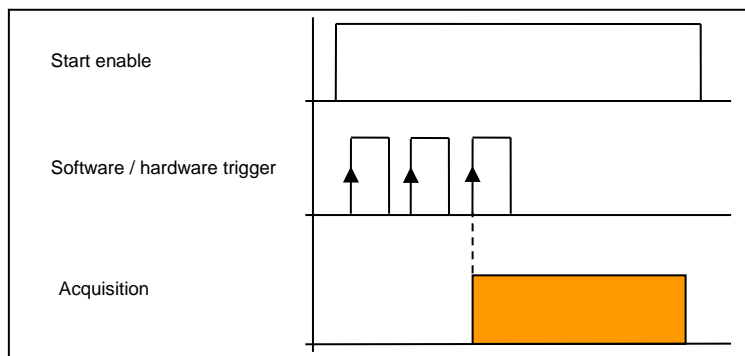

b) With “Hardware trigger active edge”, “Rising” is selected again, and with “Hardware trigger count”, the value 1 is entered.

Fig. 6-13: Hardware trigger with “One-Shot” (b)

Trigger source	Hardware trigger
Trigger mode	One-shot
Hardware trigger active edge	Rising
Hardware trigger count Number of trigger events before the acquisition starts.	1
Number of sequences per trigger Number of sequences to be acquired after each trigger event	1

The trigger starts only one acquisition, which begins with the first hardware edge after you start (see Fig. 6-8).

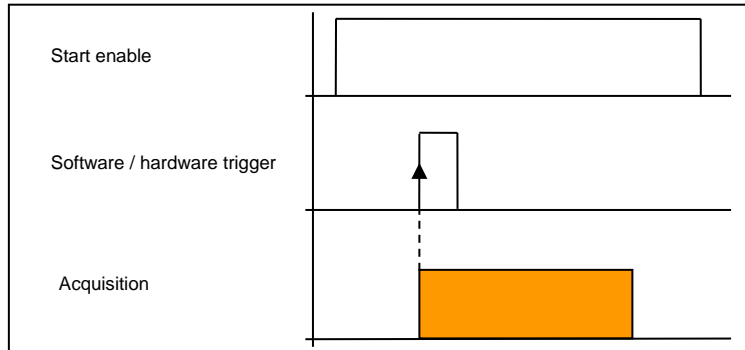

- c) With "Hardware trigger active edge", "Both" is selected, and with "Hardware trigger count", the value 3 is entered.

Fig. 6-14: Hardware trigger with "One-Shot" (c)

Trigger source	Hardware trigger
Trigger mode	One-shot
Hardware trigger active edge	Both
Hardware trigger count Number of trigger events before the acquisition starts.	3
Number of sequences per trigger Number of sequences to be acquired after each trigger event	1

After the start (see Fig. 6-8), the MSX-E system waits for three rising and falling hardware edges. Once the three edges have been identified, the acquisition starts.

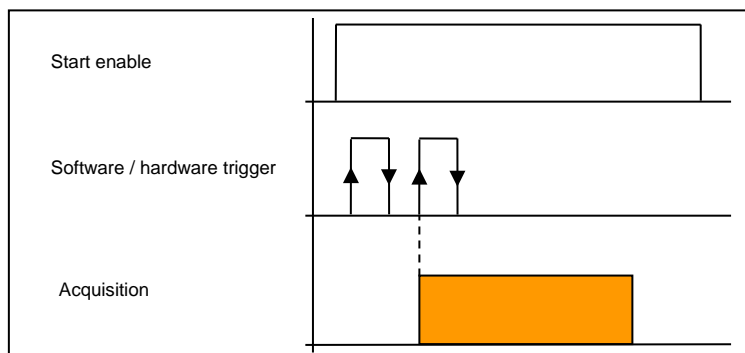

- d) With "Hardware trigger active edge", the option "Both" is selected again, and with "Hardware trigger count", the value 1 is entered.

Fig. 6-15: Hardware trigger with "One-Shot" (d)

Trigger source	Hardware trigger
Trigger mode	One-shot
Hardware trigger active edge	Both
Hardware trigger count Number of trigger events before the acquisition starts.	1
Number of sequences per trigger Number of sequences to be acquired after each trigger event	1

If several edges occur after you start (see Fig. 6-8), the acquisition is started (triggered) with the first edge. The subsequent edges are ignored.

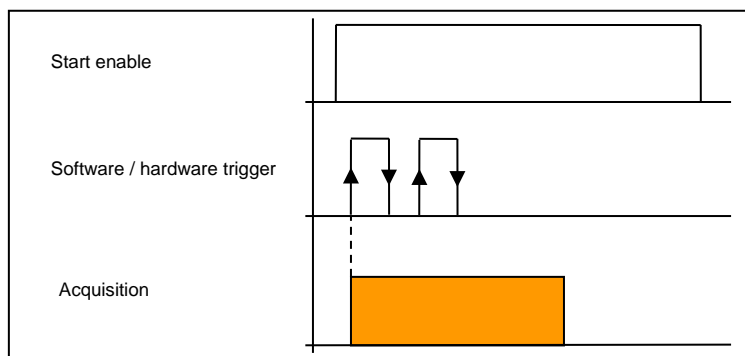

3) Examples of hardware triggers with "Sequence"

- a) To start each acquisition after one rising edge, you can use the following parameters:

Fig. 6-16: Hardware trigger with "Sequence" (a)

Trigger source	Hardware trigger
Trigger mode	Sequence
Hardware trigger active edge	Rising
Hardware trigger count Number of trigger events before the acquisition starts.	1
Number of sequences per trigger Number of sequences to be acquired after each trigger event	1

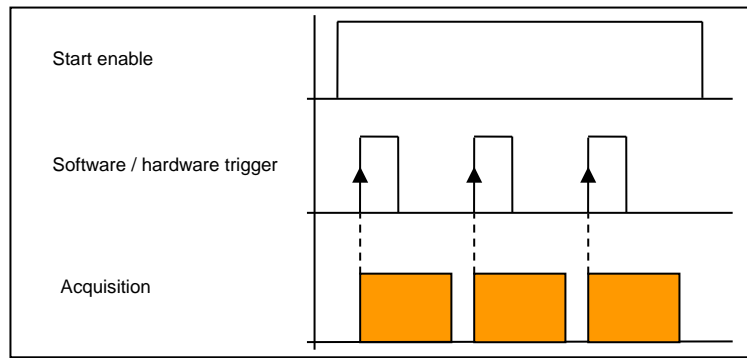

b) With "Hardware trigger active edge", "Both" is selected, and "Hardware trigger count" contains the value 3.

Fig. 6-17: Hardware trigger with "Sequence" (b)

Trigger source	Hardware trigger
Trigger mode	Sequence
Hardware trigger active edge	Both
Hardware trigger count Number of trigger events before the acquisition starts.	3
Number of sequences per trigger Number of sequences to be acquired after each trigger event	1

After you start (see Fig. 6-8), the acquisition is started after three rising and falling edges. After the end of this sequence, the next sequence is started after three rising and falling edges, and so on.

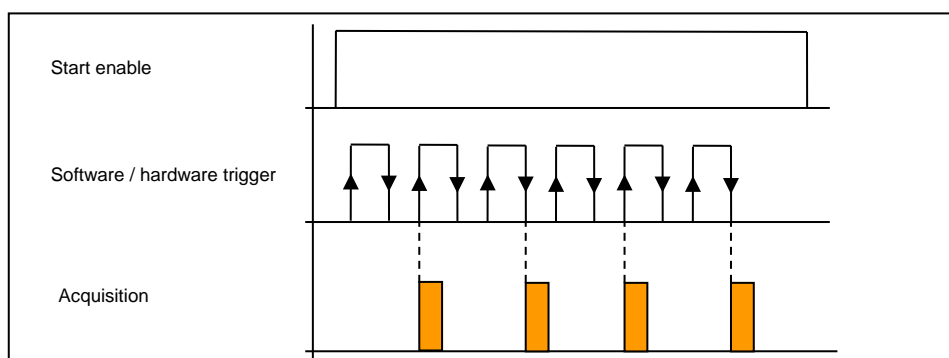



IMPORTANT!

Edges that occur during an acquisition are ignored. Only those edges are considered that occur after the end of an acquisition (see the previous and following examples).

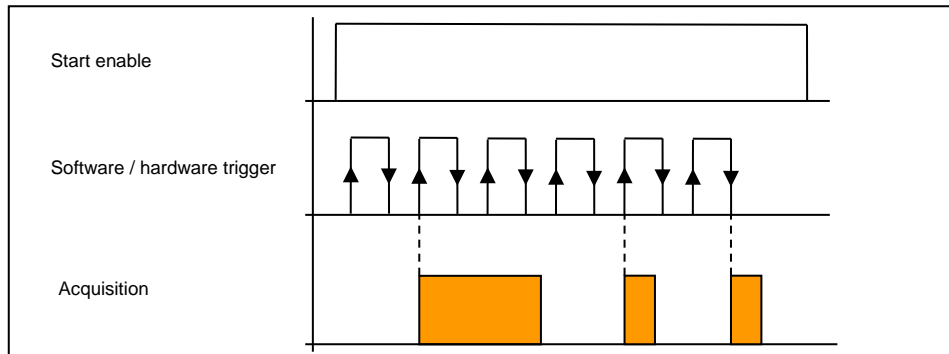

- c) The settings correspond to example 2 with the exception of "Number of sequences per trigger", where value 2 is entered.

Fig. 6-18: Hardware trigger with "Sequence" (c)

Trigger source	Hardware trigger
Trigger mode	Sequence
Hardware trigger active edge	Both
Hardware trigger count Number of trigger events before the acquisition starts.	3
Number of sequences per trigger Number of sequences to be acquired after each trigger event	2

After each trigger, two sequences are acquired.

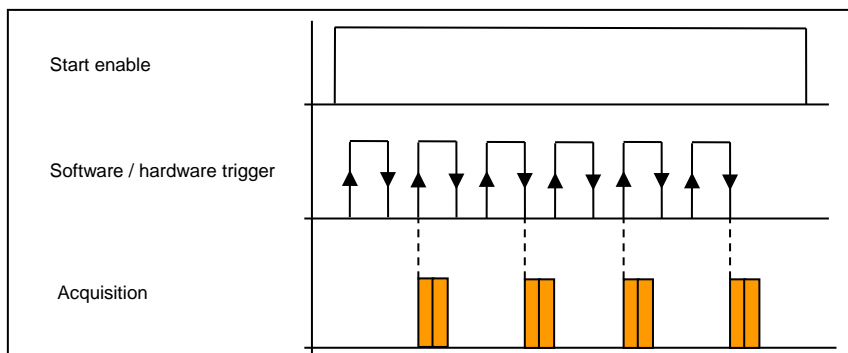

6.3.3 “Data frame” (additional data)

Fig. 6-19: Acquisition: Data frame

Data frame

You can request the MSX-E system to perform the following actions:

- Send an absolute time stamp with the data.
- Send a relative time stamp with the data, which is based on the start of the acquisition.
- Send the Auto-refresh counter with the data.
- Send the hardware trigger status with the data (D0: state low/high, D1 : 1 : falling edge occurred, D2: 1: rissing edge occurred).
- Convert the values into analog values.

By default, only the acquisition values are sent to the client. However, it can also receive additional information if you activate the following options.

- **Send an absolute time stamp with the data:** A time stamp is sent that contains the date of the acquisition.
- **Send a relative time stamp with the data:** The date of the time stamp relates to the starting point 0 of the acquisition.
- **Send the Auto-refresh (or “Sequence counter”) with the data:** The value of the Auto-refresh or Sequence counter is sent. In Auto-refresh mode, not all sequences are acquired so that the succession of the counter values is incomplete (e. g. 1, 3, 7). In Sequence mode, however, all sequences are acquired. Thus, the succession of these counter values is complete (1, 2, 3, etc.).
- **Send the hardware trigger status with the data:** The current status of the hardware trigger is indicated, i. e. if a rising or falling edge occurred.
- **Convert the values into analog values:** With this option, the MSX-E system converts the raw values immediately to the correct unit. This unit depends on the system type.

With an **MSX-E3211**, the unit is degree Celsius (°C). As the conversion affects the MSX-E CPU to a certain extent, this can result in slower sending speed.



IMPORTANT!

Please note that the digital value is an internal value of the A/D converter and thus not suitable for temperature or resistance value calculation. Please only use the analog value for this purpose!

6.3.4 “Binary data frame packet structure” (packet format)

Fig. 6-20: Acquisition: Binary data frame packet structure

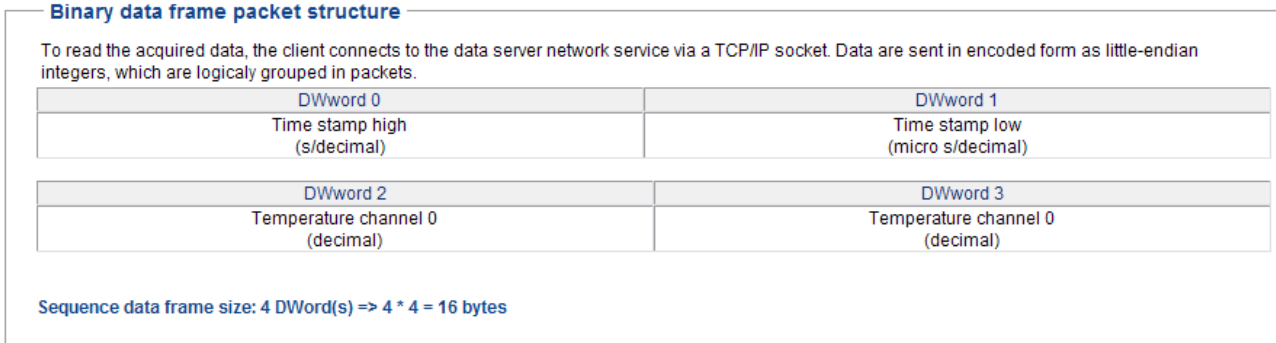

The MSX-E system sends the data over the network to one or more clients. In order that the client can interpret the values correctly, these are formatted. The format is defined as “Binary data frame packet structure”. All measurement values and the additional data such as the time stamp form a group of values that is called a packet.



IMPORTANT!

The MSX-E system sends the packets in the Intel format (Little Endian).

For more information on the data format, see Chapter 5.1.2.

Example

A packet consists of a counter value and eight measurement values. The MSX-E system always sends one or more of these packets. The data client has to be programmed in such a way that it can receive a packet and interpret it correctly.

7 Technical data and limit values

7.1 Electromagnetic compatibility (EMC)

The Ethernet system **MSX-E3211** complies with the European EMC directive. The tests were carried out by a certified EMC laboratory in accordance with the norm from the EN 61326 series (IEC 61326). The limit values as set out by the European EMC directive for an industrial environment are complied with.

The respective EMC test report is available on request.

7.2 Mechanical structure

Fig. 7-1: MSX-E3211: Dimensions

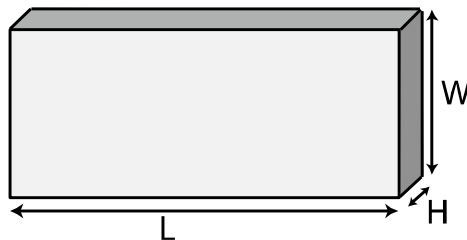

220,4 mm (L) x 140 mm (W) x 50 mm (H)

Weight:	950 g
	1010 g (with MX-Rail)

Fig. 7-2: MSX-E3211: View from above



7.3 Versions

The Ethernet system **MSX-E3211** is available in the following versions:

Table 7-1: MSX-E3211: Versions

Version	Features
MSX-E3211-TC-16	for 16 thermocouples (TC)
MSX-E3211-TC-8	for 8 thermocouples (TC)
MSX-E3211-RTD-16	for 16 resistance temperature detectors (RTD)
MSX-E3211-RTD-8	for 8 resistance temperature detectors (RTD)

The specific version name can be found on the type label of your Ethernet system (see also Chapter 1.1 of the general MSX-E manual).

7.4 Limit values

Height:	2000 m over NN
Operating temperature:	-40 °C to +85 °C
Storage temperature:	-40 °C to +85 °C

Relative air humidity at indoor installation:	50 % at +40 °C 80 % at +31 °C (Ice formation from condensation must be prevented.)
Current supply:	
Nominal voltage:	24 VDC
Supply voltage:	18-30 V
Current consumption (at 24 V):	140 mA (±10 %)
Safety:	
Degree of protection:	IP 65 ¹
Optical isolation:	1000 V



IMPORTANT!

After boot-up, the MSX-E system should warm up for a minimum 15 minutes so that a constant internal temperature will be reached.

7.4.1 Ethernet

Number of ports:	2
Optical isolation:	1000 V
Cable length:	150 m (max. for CAT5E UTP)
Bandwidth:	10 Mbps (auto-negotiation) 100 Mbps (auto-negotiation)
Protocol:	10 Base-T according to IEEE 802.3 100 Base-TX according to IEEE 802.3
MAC address:	00:0F:6C:##:##:## (unique for each device)

7.4.2 Trigger input

24 V trigger input

Number of inputs:	1
Filter/Protective circuit:	low-pass/transorb diode
Optical isolation:	1000 V (via opto-couplers)
Nominal voltage:	24 VDC

¹ The degree of protection is only provided when the relevant protection caps are used.

Input voltage:	0-30 V
Input current:	11 mA typ. (at nominal voltage)
Max. input frequency:	2 MHz (at nominal voltage)
Logic input levels:	U _{Hmax} : 30 V U _{Hmin} : 19 V U _{Lmax} : 14 V U _{Lmin} : 0 V

5 V trigger input (optional)

Number of inputs:	1
Filter/Protective circuit:	low-pass/transorb diode
Optical isolation:	1000 V (via opto-couplers)
Nominal voltage:	5 V
Input voltage:	0-5 V
Input current:	12 mA typ. (at nominal voltage)
Max. input frequency:	1 MHz (at nominal voltage)
Signal threshold:	2.2 V typ.

7.4.3 Synchro input and output

Number of inputs:	1
Number of outputs:	1
Optical isolation:	1000 V
Output type:	RS422
Driver level (master) V _{A-B} :	≤ -1.5 V (low) ≥ 1.5 V (high)
Receiver level (slave) V _{A-B} :	≤ -200 mV (low) ≥ 200 mV (high)

7.4.4 Temperature sensor inputs

Number of inputs:	8 (MSX-E3211-x-8) 16 (MSX-E3211-x-16) (2 per female connector / common GND)
Resolution:	24-bit
Real acquisition frequency:	see Table 7-2
Current source:	~ 200 µA (calibrated internally)

RTD accuracy:	see Table 7-3
TC accuracy:	see Table 7-4

Table 7-2: Real acquisition frequency

Real acquisition frequency		
on 1 channel	on 2 channels	Sampling frequency (software-selectable)
2.37 Hz	1.585 Hz	5 Hz
4.73 Hz	3.154 Hz	10 Hz
9.37 Hz	6.243 Hz	20 Hz
18.9 Hz	12.6 Hz	40 Hz
37.35 Hz	24.89 Hz	80 Hz
73 Hz	48.65 Hz	160 Hz
145 Hz	96.8 Hz	320 Hz
276.4 Hz	184.26 Hz	640 Hz
407.83 Hz	271.96 Hz	1 kHz
788 Hz	525.48 Hz	2 kHz

Table 7-3: RTD accuracy

RTD accuracy (Pt100)	Sampling frequency
-0.6 to 0.6 °C	≤ 20 Hz
-0.6 to 0.6 °C	≤ 500 Hz
-0.6 to 0.6 °C	≤ 1 kHz
-0.6 to 0.6 °C	≤ 2 kHz

Table 7-4: TC accuracy

TC accuracy incl. CJC (Types J, K)	Sampling frequency
-0.8 to 0.8 °C	≤ 20 Hz
-0.8 to 0.8 °C	≤ 500 Hz
-1.2 to 1.2 °C	≤ 1 kHz
-1.3 to 1.3 °C	≤ 2 kHz

7.5 Sensor-specific properties

The sensor-specific properties were measured under the following conditions:

Height:	180 m over NN
Ambient temperature:	+25 °C
Air humidity:	70 %

8 Appendix

8.1 Glossary

Buffer

The buffer is used for the temporary storage of information that is only needed at a later time.

Cascading

Cascading means connecting multiple similar elements together to enhance their individual effect. The individual elements must be such that the outputs of a given element are compatible with the inputs of the subsequent element in terms of values and functionality.

Counter

A counter is a circuit that counts pulses or measures pulse duration.

Data acquisition

Data acquisition means gathering information from sources such as sensors and transducers in an accurate, timely and organised manner. Modern systems convert this information to digital data which can be stored and processed by a computer.

Digital signal

A digital signal is a digital representation of a constantly changing value or other piece of information. Digital signals consist of a finite number of values. The smallest possible difference between two digital values is referred to as the resolution. Digital signals are

discontinuous in terms of value and time ranges.

EMC

= Electromagnetic Compatibility

The definition of the VDE regulation 0870 states: Electromagnetic compatibility is the ability of an electrical installation to function satisfactorily within its electromagnetic environment without unduly affecting its environment and the equipment it contains.

Ethernet

The Ethernet is a baseband bus system originally developed in order to connect mini-computers. It is based on the CSMA/CD access method. Coaxial cables or twisted-pair cables are used as the transmission medium. The transmission speeds are 10 Mbit/s (Ethernet), 100 Mbit/s (Fast Ethernet) and 1 Gbit/s or 10 Gbit/s (Gigabit-Ethernet). This widely used technology for computer networking in a LAN has been standardised since 1985 (IEEE 802.3 and ISO 8802-3). Ethernet technology is now common practice in the office environment. After making even very tough real-time requirements possible and adapting the device technology (bus cables, patch fields, junction boxes) to the harsh application conditions of the industrial environment, Ethernet is now also increasingly

used in the field areas of automation technology.

Ground line

Ground lines should not be seen as potential-free return lines. Different ground points may have small potential differences. This is always true with large currents and may cause inaccuracy in high-resolution circuits.

IEC

= International Electrotechnical Commission

The IEC is a UN body affiliated to the ISO (International Standards Organisation) which sets standards for electrotechnical parts and components.

Input level

The input level is the logarithmic ratio between two electrical values of the same type (voltage, current or power) at the signal input of any receiving unit. This unit is often configured as a logical level related to the input of the circuit. The input voltage corresponding to logic "0" is between 0 V and 15 V and the voltage corresponding to logic "1" is between 17 V and 30 V.

IP degree of protection

The IP standard defines the degree of protection of a system against dirt and water. The first figure after the "IP" (e.g. 6 in IP 65) indicates the degree of protection against solid objects penetrating the housing. The second figure indicates the degree of protection against liquids penetrating the housing. In IP 65, the figures 6 and 5 have the following

meaning: 6 = full protection against moving parts and against dirt penetration;

5 = protection against jets of water from any direction.

In IP 40, the figure 4 equates to protection against contact with small objects and protection against small foreign bodies (larger than 1 mm). The figure 0 means that there is no protection.

Level

Logic levels are defined for processing and displaying information.

In binary switches, voltages are used for digital values. Here, the two voltage ranges "H" (high) und "L" (low) represent the information.

The "H" range is closer to plus infinity; the "H" level corresponds to digital 1. "L" denotes the range closer to minus infinity; the "L" level corresponds to digital 0.

Limit value

Exceeding the limit values, even for a short time, can easily result in the destruction of the component or the (temporary) loss of functionality.

MAC address

MAC = Media Access Control

This is the hardware address of network components used to identify them uniquely within the network.

Optical isolation

Optical isolation means that there is no flow of

electrical current between the circuit to be measured and the measuring system.

Protective circuit

A protective circuit is set up on the actuator side to protect the control electronics and provide adequate EMC safety. The simplest protective circuit involves connecting a resistor in parallel.

Resolution

The resolution indicates how precisely a signal or value is held within the computer.

Short-circuit

A short-circuit exists between two terminals of an electric circuit if the relevant terminal voltage is zero.

SOAP

= Simple Object Process Protocol

SOAP is a simple extensible protocol for exchanging information in distributed environments. It defines XML messages that can be exchanged between heterogeneous applications via HTTP.

SOAP is independent of operating systems and can be integrated into existing Internet structures, including Ethernet TCP/IP-based automation concepts. SOAP is based on Remote Procedure Calls and XML. This means that functions from other platforms can be called and used from any point within the network. Any results data can also be returned using XML schemas. This enables distributed computing

capacity and non-redundant data storage in distributed systems.

TCP/IP

= Transmission Control Protocol/Internet Protocol

TCP/IP is a family of network protocols and therefore often just referred to as Internet protocol. The computers that are part of the network are identified via their IP addresses. UDP is another transport protocol that belongs to the core group of this protocol family.

Trigger

A trigger is a pulse or signal for starting or stopping a special task. Triggers are often used for controlling data acquisition.

UDP

= User Datagram Protocol

This is a minimal connection-free network protocol which is part of the transport layer within the Internet protocol family. The purpose of UDPs is to ensure that data transmitted over the Internet reach the correct application.

8.2 Index

- Acquisition mode 28
 - Auto-refresh mode 28
 - Sequence mode 30
- Block diagram 12
- Brief description 11
- Connection examples
 - RTD sensors 23
 - TC sensors 22
- Country-specific regulations 9
- Dimensions 43
- EMC 43
- Functions 11
- Glossary 48
- Handling 10
- Intended use 8
- Limit values 44
- Packet format 42
- Pin assignment
 - RTD inputs 21
 - TC inputs 20
- Safety precautions 8
- Sequences 31
- Technical data 43
- Temperature sensor inputs
 - Function description 20
- Temperature sensors 13
 - Resistance temperature detectors 17
 - Thermocouples 13
- Time stamp 41
- Trigger
 - Configuration 34
 - Hardware trigger 36
- Update
 - Driver 10
 - Firmware 10
 - Manual 10
- Usage restrictions 8
- User
 - Qualification 9
- Versions 44
- Web interface
 - I/O Configuration 25

9 Contact and support

Do you have any questions? Write or phone us:

Address: ADDI-DATA GmbH
Airpark Business Center
Airport Boulevard B210
77836 Rheinmünster
Germany

Phone: +49 7229 1847-0

Fax: +49 7229 1847-222

E-mail: info@addi-data.com

Manual and software download from the Internet:

www.addi-data.com